

BR-1225A

DIMENSIONS (MM)

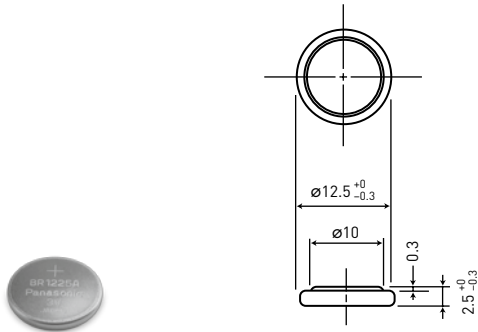

Model number	BR-1225A
Nominal voltage (V)	3
Nominal capacity (mAh)	48
Diameter (mm)	12.5
Total height (mm)	2.5
Discharging temperature range (°C)	-40 to +125
Weight (g)	0.8

DISCHARGE TEMPERATURE CHARACTERISTICS

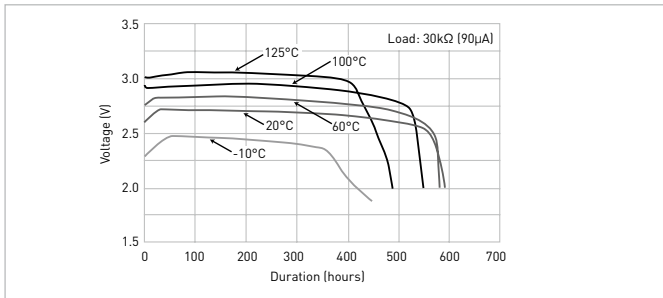

BR-1632A

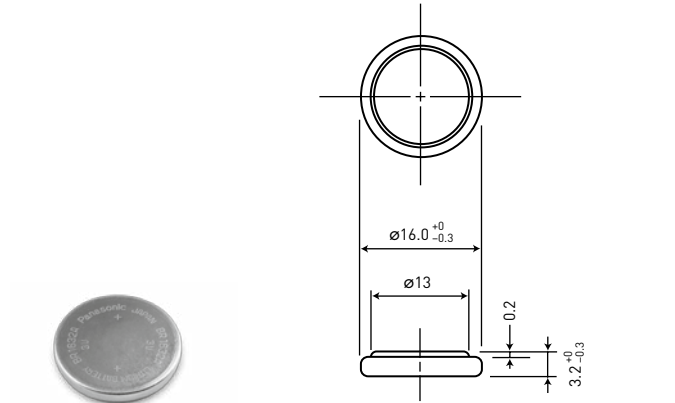

Model number	BR-1632A
Nominal voltage (V)	3
Nominal capacity (mAh)	120
Diameter (mm)	16.0
Total height (mm)	3.2
Discharging temperature range (°C)	-40 to +125
Weight (g)	1.5

DISCHARGE TEMPERATURE CHARACTERISTICS

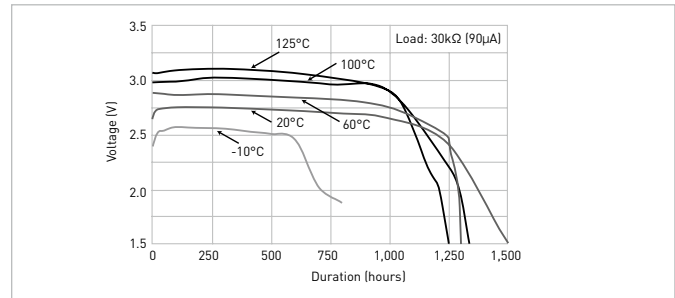

BR-2330A

DIMENSIONS (MM)

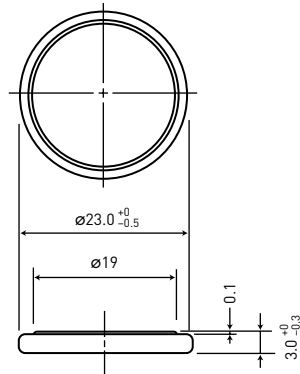

Model number	BR-2330A
Nominal voltage (V)	3
Nominal capacity (mAh)	255
Diameter (mm)	23.0
Total height (mm)	3.0
Discharging temperature range (°C)	-40 to +125
Weight (g)	3.2

DISCHARGE TEMPERATURE CHARACTERISTICS

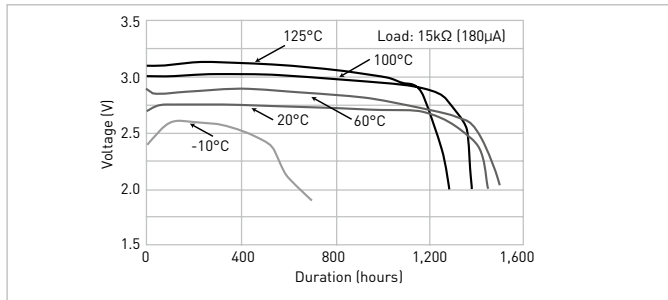

BR-2450A

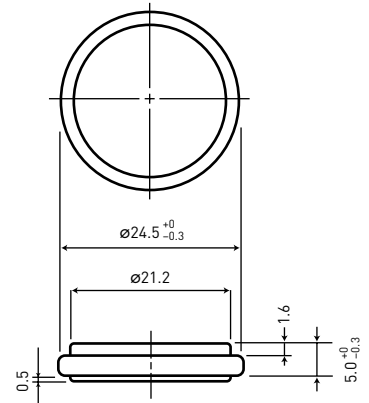

Model number	BR-2450A
Nominal voltage (V)	3
Nominal capacity (mAh)	550
Diameter (mm)	24.5
Total height (mm)	5.0
Discharging temperature range (°C)	-40 to +125
Weight (g)	5.9

DISCHARGE TEMPERATURE CHARACTERISTICS

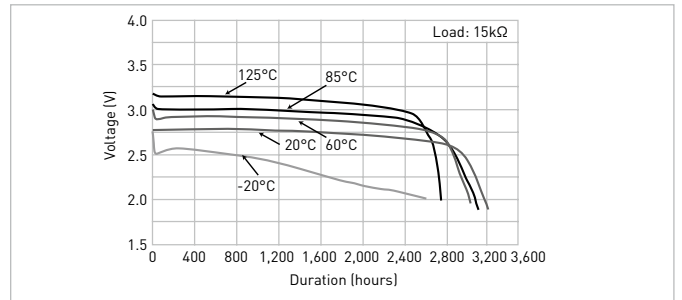

BR-2477A

DIMENSIONS (MM)

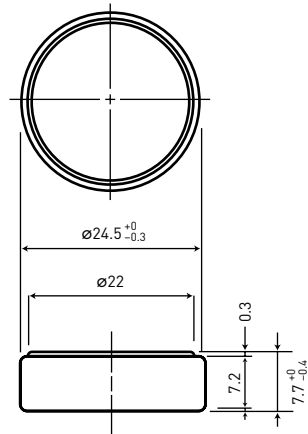

Model number	BR-2477A
Nominal voltage (V)	3
Nominal capacity (mAh)	1,000
Diameter (mm)	24.5
Total height (mm)	7.7
Discharging temperature range (°C)	-40 to +125
Weight (g)	8.0

DISCHARGE TEMPERATURE CHARACTERISTICS

