

# Industrial and general purpose gate driver ICs

Selection guide 2017

[www.infineon.com/gatedriver](http://www.infineon.com/gatedriver)  
[www.infineon.com/eicedriver](http://www.infineon.com/eicedriver)

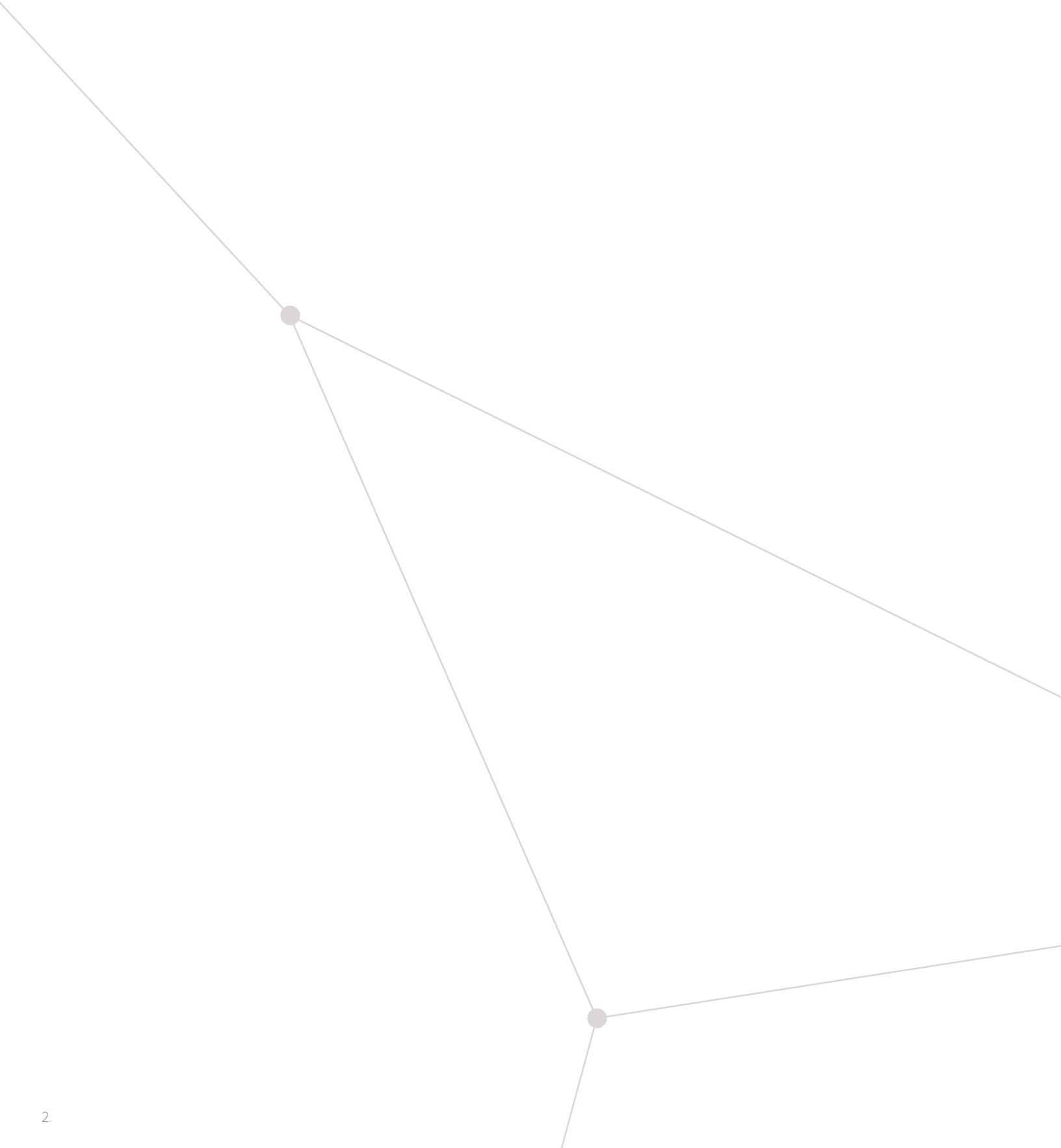



# Contents

<b>Infinion gate driver IC technologies</b>	<b>4</b>	<b>New product highlights</b>	<b>26</b>
Junctional isolation technology	7	IRS2890DS 600-V gate driver IC	26
Infinion SOI technology	8	IRS200x 200-V gate driver family	27
Infinion CT isolation technology	10	2EDL half-bridge drivers with BSD	28
Silicon carbide drive requirements	12	1EDI20I12SV isolated drivers with SRC	29
		1EDI compact isolated drivers	30
		1EDN and 2EDN low-side families	31
<b>Product portfolio overview</b>	<b>14</b>		
Half-bridge gate driver ICs	14	<b>Gate driver IC support</b>	<b>32</b>
Three-phase gate driver ICs	16	Gate driver selection tool	32
High-side gate driver ICs	17	Infinion Designer	32
High-side and low-side gate driver ICs	19	EiceDRIVER™ evaluation boards	33
Low-side gate driver ICs	20	Gate driver IC chips for integrators	34
Complementary products: Current sense ICs	21		
Complementary products: Start-up IC	21		
Complementary products: Opto-isolated solid state relays	22		
Complementary products: Opto-isolated gate drivers/voltage sources	23		

# Infineon gate driver IC technologies

Leveraging the application expertise and advanced technologies of Infineon and International Rectifier, the industrial and general purpose gate driver ICs are well suited for many application such as major home appliances, industrial motor drives, solar inverters, UPS, switched-mode power supplies, and high-voltage lighting. Infineon offers a comprehensive portfolio with a variety of configurations, voltage classes, isolation levels, protection features, and package options. These flexible gate driver ICs are complementary to Infineon IGBTs, silicon and silicon carbide MOSFETs (CoolMOS™ and CoolSiC™), or as part of integrated power modules. Every switch needs a driver.



**Level-shifting p-n junction isolation (LS-JI)** technology is a mature, proven industry standard MOS/CMOS fabrication technique. Infineon's proprietary HVIC and latch-immune CMOS technologies enable ruggedized monolithic construction. The advanced process allows monolithic high-voltage and low-voltage circuitry construction with the best price per performance.

**Main benefits of JI technology:**

- > High current capability
- > Precision analog circuitry (tight timing/propagation delay)
- > Most comprehensive portfolio with industry-standard gate drivers
  - **Voltage classes:** 1200 V, 700 V, 600 V, 200 V, and 100 V
  - **Configurations:** three-phase, half-bridge, single channel, and more
- > Drivers tailored towards the best price per performance



**Level-shifting silicon-on-insulator (LS-SOI)** technology is an advanced fabrication technique used for Infineon EiceDRIVER™ SOI products. The silicon is separated from the substrate by a buried oxide layer. The top layer, which is the silicon film, is used to produce the transistor. The bottom layer is used as the silicon substrate. The buried silicon dioxide provides an insulation barrier between the active layer and silicon substrate. The advanced process allows monolithic high-voltage and low-voltage circuitry construction with additional technology-enhanced features.

**Main benefits of Infineon SOI technology:**

- > Best-in-class immunity to negative transients prevents erratic operation and latch-up while improving reliability
- > Low-ohmic integrated bootstrap diode has the lowest reverse recovery losses resulting in reduced power losses
- > Minimum level-shift losses improve driver efficiency and allows flexible housing designs
- > 600 V and higher withstand voltages for operating margin
- > Integrated filters



**Coreless transformer (CT)** technology is an isolated technology which uses semiconductor manufacturing processes to integrate an on-chip transformer consisting of metal spirals and silicon oxide insulation. These coreless transformers are used for transmitting switching information between input chip and output chip. Two isolated chips ensure galvanic isolation.

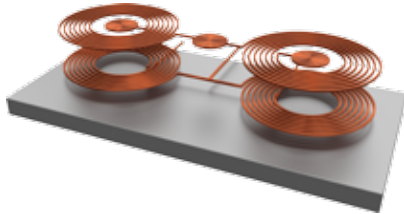

**Main benefits of CT technology:**

- > Galvanic isolation
- > Allows very large voltage swings of  $\pm 1200$  V or larger
- > Immunity against negative and positive transients
- > Increases reliability of the end product
- > Low losses and low power dissipation



**Non-isolated (NI)** technology refers to gate drivers utilizing low-voltage circuitry. Infineon's world-class fabrication techniques enable high-current gate drivers for high-power-density applications in industry standard DSO-8 and small form-factor SOT23 and WSON packages.

## Typical applications

<table border="0"> <tr> <td style="text-align: center;">Aircon </td> <td style="text-align: center;">Major home appliance </td> <td style="text-align: center;">Fridge </td> </tr> <tr> <td style="text-align: center;">Dishwasher </td> <td style="text-align: center;">Laundry dryer </td> <td style="text-align: center;">Vacuum cleaner </td> </tr> <tr> <td style="text-align: center;">Power tools </td> <td style="text-align: center;">Multicopter </td> <td style="text-align: center;">LEV </td> </tr> <tr> <td style="text-align: center;">SMPS </td> <td style="text-align: center;">Induction </td> <td style="text-align: center;">Home &amp; garden </td> </tr> <tr> <td style="text-align: center;">Consumer </td> <td style="text-align: center;">Electric toys </td> <td style="text-align: center;">PFC </td> </tr> </table>	Aircon 	Major home appliance 	Fridge 	Dishwasher 	Laundry dryer 	Vacuum cleaner 	Power tools 	Multicopter 	LEV 	SMPS 	Induction 	Home & garden 	Consumer 	Electric toys 	PFC 	<p style="text-align: center;"><b>Level-shifting technology (LS-SOI) &amp; (LS-JI)</b></p> <table border="0" style="margin: 0 auto;"> <tr> <td style="text-align: center;">Motor control </td> <td style="text-align: center;">Fans </td> </tr> <tr> <td style="text-align: center;">Pumps </td> <td style="text-align: center;">Welding </td> </tr> <tr> <td style="text-align: center;">Server </td> <td style="text-align: center;">Telecom </td> </tr> </table>	Motor control 	Fans 	Pumps 	Welding 	Server 	Telecom 	<p style="text-align: center;"><b>Coreless transformer (CT) technology</b></p> <table border="0" style="margin: 0 auto;"> <tr> <td style="text-align: center;">UPS </td> <td style="text-align: center;">Drives </td> <td style="text-align: center;">Solar </td> </tr> <tr> <td style="text-align: center;">LV-drives </td> <td style="text-align: center;">Automation </td> <td style="text-align: center;">EV-Charging </td> </tr> </table>	UPS 	Drives 	Solar 	LV-drives 	Automation 	EV-Charging 
Aircon 	Major home appliance 	Fridge 																											
Dishwasher 	Laundry dryer 	Vacuum cleaner 																											
Power tools 	Multicopter 	LEV 																											
SMPS 	Induction 	Home & garden 																											
Consumer 	Electric toys 	PFC 																											
Motor control 	Fans 																												
Pumps 	Welding 																												
Server 	Telecom 																												
UPS 	Drives 	Solar 																											
LV-drives 	Automation 	EV-Charging 																											



# Junctional isolation technology

Pioneered by International Rectifier since 1984 with the introduction of the first monolithic product, the high-voltage integrated circuit (HVIC) technology uses patented and proprietary monolithic structures integrating bipolar, CMOS, and lateral DMOS devices with breakdown voltages above 700 V and 1400 V for operating offset voltages of 600 V and 1200 V. Using this mixed signal HVIC technology, both high-voltage level-shifting circuits and low-voltage analog and digital circuits can be implemented. With the ability to place high-voltage circuitry (in a 'well' formed by polysilicon rings) that can 'float' 600 V or 1200 V on the same silicon away from the rest of the low-voltage circuitry, high-side power MOSFETs or IGBTs that exist in many popular off-line circuit topologies such as buck, synchronous boost, half-bridge, full-bridge and three-phase.

These HVIC gate drivers with floating switches are well suited for topologies requiring high-side and bridge configurations.

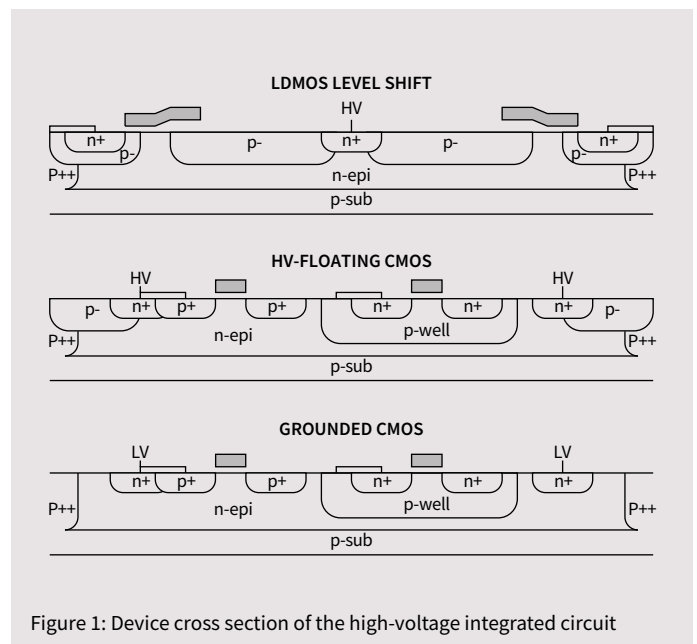
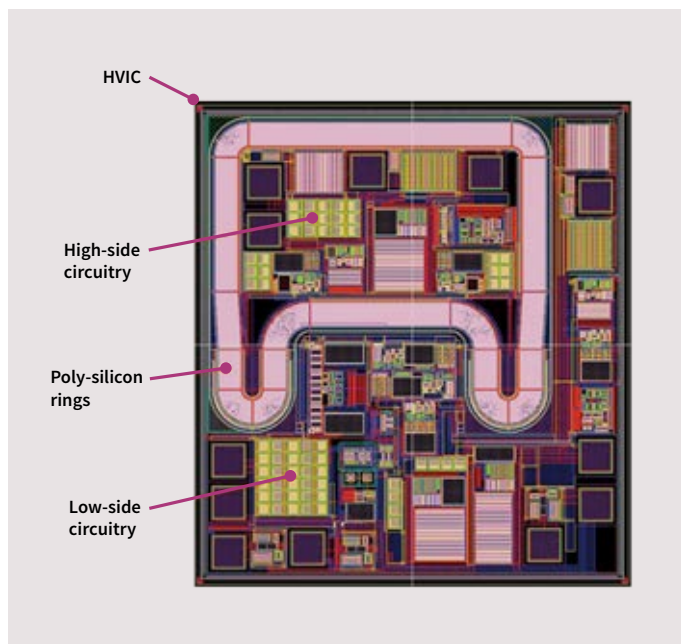
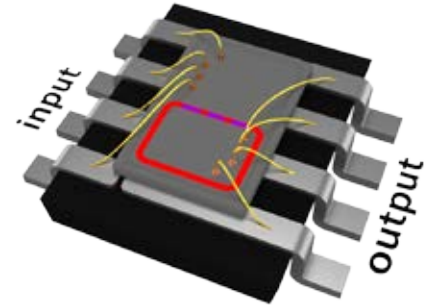

Figure 1: Device cross section of the high-voltage integrated circuit

# Infineon SOI technology

EiceDRIVER™ products with Infineon SOI technology provides unique, measurable, best-in-class advantages.

## Negative $V_s$ transient ( $-V_s$ ) operation robustness

In a today's high-power switching converters carrying a large load current, the  $V_s$  voltage swing does not stop at the level of the negative DC bus but instead swings below the level of the negative DC bus due to the parasitic inductances in the power circuit from the die bonding to the PCB tracks. This undershoot voltage is called "negative  $V_s$  transient". High-voltage

EiceDRIVER™ products using Infineon SOI have the best-in-the-industry operational robustness. In Figure 3, the safe operating line is shown at  $V_{BS} = 15$  V for pulse widths up to 1000 ns. Above this line, the products do not show unwanted functional anomalies or permanent damage to the IC.

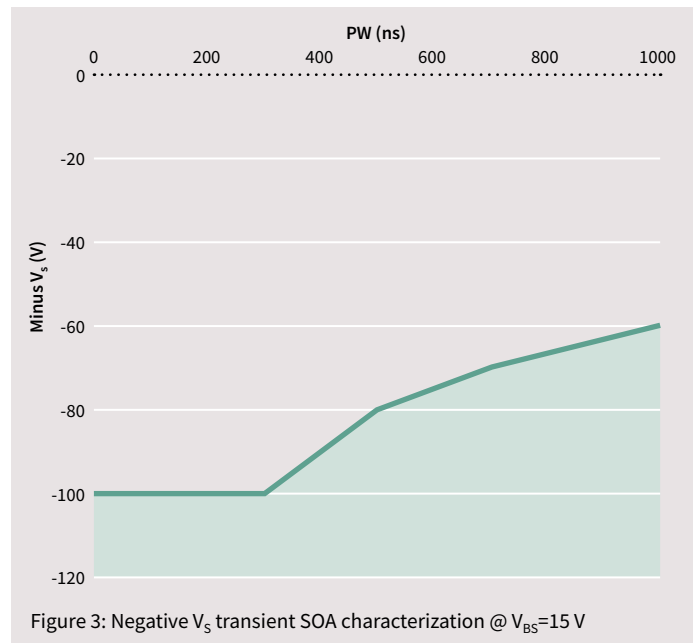
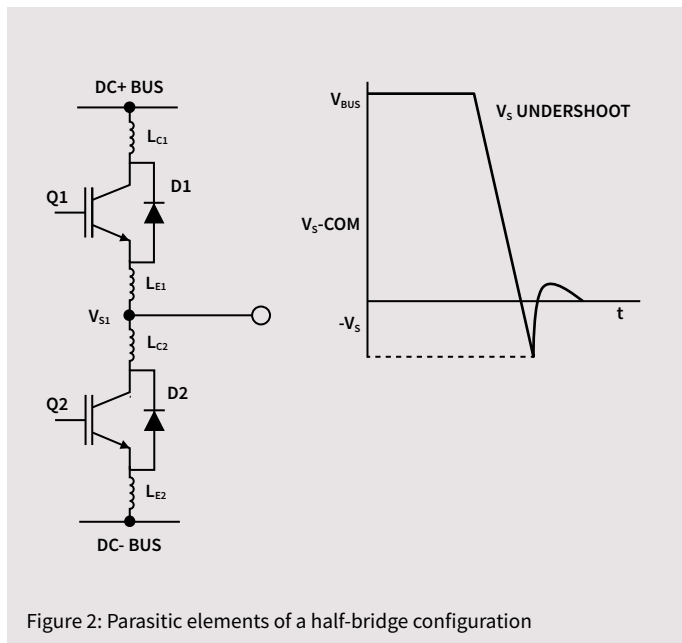





## Integrated bootstrap diode

The bootstrap power supply is one of the most common techniques for supplying power to the high-side driver circuitry due to its simplicity and low cost. As shown in Figure 4, the bootstrap power supply consists of a bootstrap diode and capacitor. The floating channel of JI drivers is typically designed for bootstrap operation. Infineon SOI drivers features excellent ultra-fast bootstrap diodes. The low diode resistance of  $R_{BS} \leq 40 \Omega$  enables a wide control range. The Infineon SOI drivers with this feature can drive larger IGBTs without the risk of self-heating, minimize BOM count, and reduce system cost.

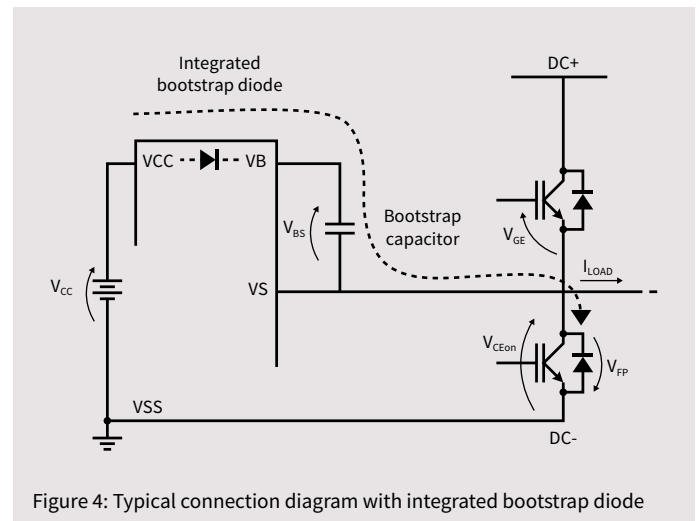

Figure 4: Typical connection diagram with integrated bootstrap diode

## Level shift losses

Level-shift losses can be a very significant part as the operating frequency increases. A level-shift circuit is used to transmit the switching information from the low-side to the high-side. The necessary charge of the transmission determines the level-shift losses. EiceDRIVER™ high-voltage products using the Infineon SOI technology requires a very low charge

to transmit the information. Minimizing level-shifting power consumption allows design flexibility of higher frequency operations, as well as longer lifetime, improved system efficiency and application reliability.

# Infineon isolation CT technology

Infineon EiceDRIVER™ galvanically isolated products uses the magnetically-coupled coreless transformer (CT) technology to provide signal transfer across galvanic isolation. The technology provides short propagation delay, excellent delay matching, and strong robustness. The isolation allows very large voltage swings (e.g.  $\pm 1200$  V).

## Robustness

- › Extremely robust signal transfer independent of common mode noise
- › Stability against common mode noise up to 100 V/ns
- › Tight propagation delay variation: Tolerance improves application robustness without variations due to age, current, and temperature

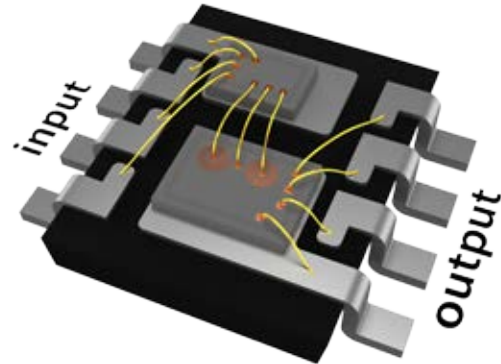

## Design flexibility

- › Wide range of gate voltages including negative gate voltage
- › CT technology is ready for use with silicon carbide MOSFETs
- › Closed-loop gate current control option

## Precise timing control

- › Precise integrated filters reduce the propagation delay and propagation delay variation over a wide range of operating conditions
- › Integrated filters reduce the effort for external filters
- › Tight propagation delay allows minimum deadtime and improved system efficiency

Integrated ramp-based filter

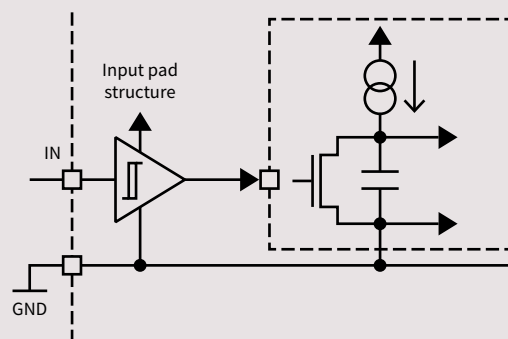

## Protection

- > Short dead times with tight propagation delay matching and precise integrated filters over a wide range of operating conditions
- > Fast short-circuit shut down using optional fast DESAT detection and two-level turn-off for short-circuit current protection
- > Reliable short-circuit detection via a fast and accurate desaturation (DESAT) detection circuit protects the power switches from damage during short-circuit condition
- > Active miller clamping option protects against parasitic turn-on due to high  $dV/dt$
- > Built in short-circuit clamping clamps the gate drive voltage during short circuit and lowers collector voltage overshoot

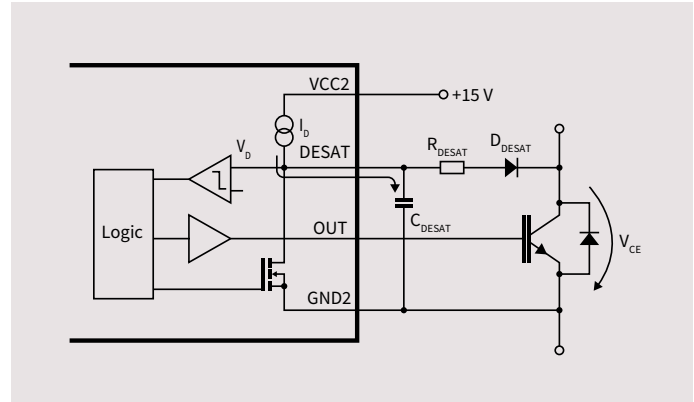

Coupling method	Tolerance $I_b$	Tolerance $V_b$
Coreless transformer	$\pm 10\%$	-8/+6%
Capacitive	$\pm 18\%$	-8/+6%
Optical	-48/+32%	$\pm 11\%$

## Safety certification

- > Safety certification available for VDE0884 and UL1577



## For SiC MOSFET switching

- > Ideal for ultra-fast switching 1200 V silicon carbide power transistors such as CoolSiC™ MOSFETs
- > The drivers incorporate most important key features and parameters for SiC driving:
  - Tight propagation delay matching
  - Precise input filters
- Wide output side supply range
- Negative gate voltage capability
- Extended common mode transient immunity (CMTI) capability

# Silicon carbide drive requirements







## CoolSiC™ MOSFETs and modules

Infinion's CoolSiC™ silicon carbide (SiC) MOSFETs open new degrees of freedom for designers to improve efficiency and system flexibility.

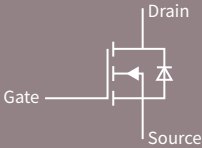
The CoolSiC™ MOSFET offers advantages of the lowest gate charge and device capacitance levels in 1200 V switches, no reverse recovery losses of the internal body diode, temperature-independent low switching losses, and threshold-free on-state characteristics. Infineon's unique 1200 V SiC MOSFET adds additional advantages of superior gate-oxide reliability enabled by state-of-the-art trench design, best in class

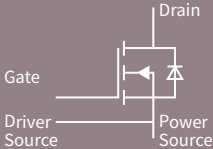
switching and conduction losses, highest transconductance (gain), full turn-on capability with gate voltage of only +15 V and short-circuit robustness.

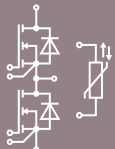
The result is a robust SiC MOSFET which is ideal for hard- and resonant-switching topologies. It can be driven like an IGBT using standard drivers delivering the highest level efficiency at switching frequencies unreachable by Si based switches allowing for system size reduction, higher power density and improved lifetime reliability.

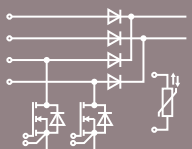



Lead products				
Schematic	Type	$R_{DS(ON)}$	$V_{DS}$	Package
Single switch 	IMW120R045M1	45 mΩ	1200 V	TO247-3pin 
Single switch 	IMZ120R045M1	45 mΩ	1200 V	TO247-4pin 
Half bridge with NTC 	FF11mR12W1M1_B11	11 mΩ	1200 V	Easy1B PressFIT 
	FF23mR12W1M1_B11	23 mΩ	1200 V	
Booster with NTC 	DF11mR12W1M1_B11	11 mΩ	1200 V	
	DF23mR12W1M1_B11	23 mΩ	1200 V	

Selectively sampling on request.

## Recommended gate drivers

Ultra-fast switching 1200 V power transistors such as CoolSiC™ MOSFETs can be easier handled by means of isolated gate output sections. Therefore, the following galvanically isolated EiceDRIVER™ ICs based on Infineon's coreless transformer technology are recommended as most suitable. For a larger selection of isolated gate drivers,

please refer to the product portfolio overview section of the selection guide. The drivers incorporate most important key features and parameters for SiC driving such as tight propagation delay matching, precise input filters, wide output-side supply range, negative gate voltage capability, and extended CMTI capability.

Recommended gate drivers									
Product	Part number	Typ. peak drive current	VCC2-VEE2	Typ. prop. delay	Typ. UVLO		Miller clamp	Other key features	Package
					ON	OFF			
1EDI compact isolated high-side driver family	1EDI20N12AF	3.5 A	35 V	≤ 120 ns	10 V	8.5 V	No	Functional isolation	DSO-8 150 mil 
	1EDI60N12AF	9.4 A	35 V	≤ 120 ns	10 V	8.5 V	No		
	1EDI20I12MF	3.5 A	20 V	≤ 300 ns	12.7 V	11.1 V	Yes		
	1EDI20H12AH	3.5 A	35 V	≤ 125 ns	12.7 V	11.1 V	No	8 mm creepage clearance	DSO-8 300 mil 
	1EDI60H12AH	9.4 A	35 V	≤ 125 ns	12.7 V	11.1 V	No		
	1EDI20I12MH	3.5 A	20 V	≤ 300 ns	12.7 V	11.1 V	Yes		
1ED-F2 isolated high-side driver with integrated protection	1ED020I12-F2	2.0 A	28 V	≤ 170 ns	12.6 V	11 V	Yes	Short circuit clamping; DESAT protection; active shutdown	DSO-16 
2ED-F2 isolated dual high-side driver with integrated protection	2ED020I12-F2	2.0 A	28 V	≤ 170 ns	12.6 V	11 V	Yes	Short circuit clamping; DESAT protection; active shutdown	DSO-36 
1ED slew rate control (SRC) isolated high-side driver	1EDI20I12SV	2.0 A	28 V	≤ 485 ns			Yes	Real-time adjustable gate current control; over-current protection, soft turn-off shut down, two-level turn-off	DSO-36 

# Product portfolio overview

Infinion's gate driver IC solutions are the expert's choice. With more than 200 reliable and efficient gate driver solutions, we provide a comprehensive portfolio for virtually any application. To ease the selection process, this overview is structured along the configurations of the gate driver ICs, as opposed to by application topology.

Half-bridge gate driver ICs				Technology	Comparator	Current amplifier	Desaturation protection	Enable	Fault reporting	Integrated bootstrap diode	Over-current protection	Programmable dead time	Programmable shutdown	Self-oscillating	Separate pin for logic ground	Shoot-through protection	Shutdown	Soft over-current shutdown	Under-voltage lockout	DSO-8	DSO-14	DSO-18	DIP-8	DIP-14	SSOP-24	VQFN-14	CHIP		
Voltage class [V]	I <sub>o+</sub> /I <sub>o-</sub> typ [mA]	Typ. prop. delay: off/on [ns]	Base PN																									Features (see page 24)	
1200	1500/2500	85/85	2ED020I12-FI	CT	✓	✓										✓	✓		✓		✓								
	2000/3000	440/440	IR2214	J1			✓	✓								✓	✓	✓	✓						✓				
700	78/169	220/220	IR7304	J1												✓			✓	✓									
	1900/2300	270/680	IR7184	J1												✓	✓	✓	✓										
650	1500/2500	85/85	2ED020I06-FI	CT												✓	✓	✓	✓			✓							
600	78/169	220/220	IR2304	J1												✓		✓	✓			✓							
			IR25601	J1													✓		✓	✓									
	180/260	na	IR21531	J1								✓	✓			✓	✓	✓	✓	✓			✓					✓	
			IR21531D	J1					✓			✓	✓			✓	✓	✓	✓	✓			✓						
			IR25603	J1								✓	✓			✓	✓	✓	✓	✓			✓						
			IRS2153(1)D	J1					✓			✓	✓			✓	✓	✓	✓	✓	✓			✓				✓	
	200/350	200/220	IR2108	J1													✓		✓	✓			✓						
			IR21084	J1							✓					✓	✓		✓	✓			✓			✓			
			IR2308	J1													✓		✓	✓			✓						
			IR25606	J1													✓		✓	✓									
		200/750	IR2109	J1													✓	✓	✓	✓			✓						
			IR21091	J1								✓				✓	✓	✓	✓	✓			✓						
			IR21094	J1								✓				✓	✓	✓	✓	✓			✓			✓			
			IR2302	J1													✓	✓	✓	✓			✓						
	210/360	150/680	IR2103	J1													✓	✓	✓	✓			✓						
			IR25602	J1													✓	✓	✓	✓									
	220/480	500/500	IRS2890D*	J1					✓	✓	✓					✓		✓	✓			✓							
	290/600	150/750	150/150	IR2111	J1												✓		✓	✓			✓						
				IRS2304	J1													✓		✓	✓			✓					✓
		150/680	IRS2103	J1													✓		✓	✓			✓					✓	
IRS2104			J1													✓	✓	✓	✓			✓					✓		
150/750		IRS2111	J1													✓		✓	✓			✓					✓		
		IRS2108	J1													✓		✓	✓			✓					✓		
200/220		IRS2308	J1													✓		✓	✓			✓					✓		
		IRS21084	J1								✓				✓	✓	✓	✓	✓			✓			✓				
200/750		IRS2109	J1													✓	✓	✓	✓			✓					✓		

\*New



## Half-bridge gate driver ICs

Typical connection

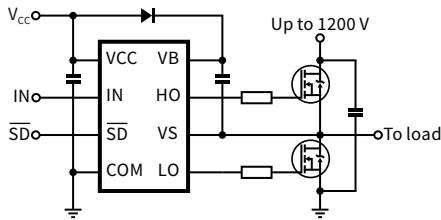

Voltage class [V]	I <sub>O</sub> /I <sub>O</sub> typ [mA]	Typ. prop. delay: off/on [ns]	Base PN	Technology	Comparator	Current amplifier	Desaturation protection	Enable	Fault reporting	Integrated bootstrap diode	Over-current protection	Programmable dead time	Programmable shutdown	Self-oscillating	Separate pin for logic ground	Shoot-through protection	Shutdown	Soft over-current shutdown	Under-voltage lockout	DSO-8	DSO-14	DSO-18	DIP-8	DIP-14	SSOP-24	VQFN-14	CHIP
					Features (see page 24)															Package (see page 25)							
600	360/700	300/310	2EDL05N06P	SOI						✓					✓			✓	✓	✓							
		400/420	2EDL05I06P	SOI						✓						✓			✓	✓	✓						
	1900/2300	220/180	IRS2183	J1												✓			✓	✓			✓				✓
			IR2183	J1													✓			✓	✓			✓			
		IR(S)21834	J1								✓					✓	✓		✓	✓		✓		✓			
		270/680	IRS2184	J1													✓	✓		✓	✓		✓				
	IR2184		J1													✓	✓		✓	✓		✓					
	IR21844		J1									✓				✓	✓	✓	✓	✓		✓		✓			
	IRS21844		J1									✓				✓	✓	✓	✓	✓		✓		✓		✓	
	2000/3000	440/440	IR2114	J1			✓	✓							✓	✓		✓	✓					✓			
2300/2800	300/310	2EDL23N06P	SOI					✓	✓	✓	✓				✓	✓		✓	✓		✓						
	400/420	2EDL23I06P	SOI					✓	✓	✓	✓				✓	✓		✓	✓		✓						
200	290/600	150/680	IRS2003	J1											✓					✓		✓					
			IRS2008*	J1												✓					✓						
			IRS2004	J1												✓	✓				✓		✓				✓

\*New

### Three-phase gate driver ICs

#### Typical connection

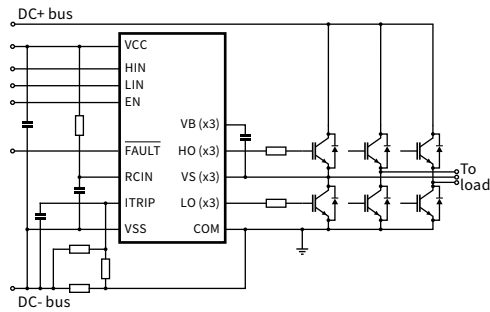

Voltage class [V]	I <sub>O+</sub> /I <sub>O-</sub> typ [mA]	Typ. prop. delay: off/on [ns]	Base PN	Technology	Current amplifier	Desaturation protection	Enable	Fault reporting	Integrated bootstrap diode	Output for brake chopper	Over-current protection	Separate pin for logic ground	Shutdown	Under-voltage lockout	DSO-20 WB	DSO-28 WB	DIP-28	LCC-32	MQFP-64	TSSOP-28	VQFN-28	VQFN-34	CHIP				
					Features (see page 24)										Package (see page 25)												
1200	250/500	700/750	IR2233	J1	✓			✓		✓	✓	✓	✓	✓	✓	✓	✓						✓				
			IR2235	J1	✓			✓		✓	✓	✓	✓	✓	✓	✓	✓	✓									
	350/450	550/550	IR2238	J1		✓		✓		✓	✓	✓	✓	✓					✓								
600	165/375	490/530	6ED003L06-F2	SOI			✓	✓		✓	✓	✓	✓	✓	✓	✓							✓				
			6EDL04I06(N,P)	SOI			✓	✓	✓		✓	✓	✓	✓	✓	✓	✓							✓			
			530/530	6EDL04N06P	SOI			✓	✓	✓		✓	✓	✓	✓	✓	✓	✓							✓		
	200/350	400/425		IR2136	J1			✓	✓		✓	✓	✓	✓	✓	✓	✓	✓						✓			
				IR21363	J1			✓	✓		✓	✓	✓	✓	✓	✓	✓	✓							✓		
				IR21365	J1			✓	✓		✓	✓	✓	✓	✓	✓	✓	✓								✓	
				IR21368	J1			✓	✓		✓	✓	✓	✓	✓	✓	✓	✓								✓	
		530/500			IR21364	J1			✓	✓		✓	✓	✓	✓	✓	✓	✓								✓	
					IRS2334	J1											✓	✓						✓			
					IRS2336	J1			✓	✓			✓	✓	✓	✓	✓	✓	✓		✓						
					IRS2336D	J1			✓	✓	✓		✓	✓	✓	✓	✓	✓	✓		✓	✓		✓			✓
					IRS23364D	J1			✓	✓	✓		✓	✓	✓	✓	✓	✓	✓		✓	✓					
	IRS23365D	J1			✓	✓	✓		✓	✓	✓	✓	✓	✓	✓							✓					
	250/500	425/675		IR213(0,2)	J1	✓			✓		✓	✓	✓	✓	✓	✓	✓	✓	✓						✓		
				300/1300	IR2131	J1				✓		✓	✓	✓	✓	✓	✓	✓	✓	✓							
700/750				IR2133	J1	✓			✓		✓	✓	✓	✓	✓	✓	✓	✓									
				IR2135	J1	✓			✓		✓		✓	✓	✓	✓	✓	✓	✓							✓	
200	165/375	490/530	6ED003L02-F2	SOI			✓	✓		✓	✓	✓	✓	✓							✓						
			530/530	6EDL04N02P	SOI			✓	✓	✓		✓	✓	✓	✓	✓						✓					



## Single high-side gate driver ICs

Typical connection

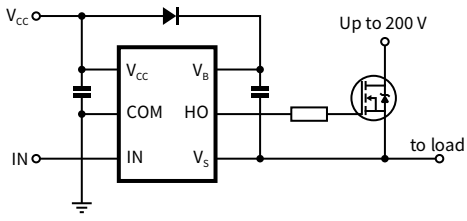

Voltage class [V]	I <sub>OH</sub> /I <sub>OL</sub> typ [mA]	Typ. prop. delay: off/on [ns]	Base PN	Technology	Features (see page 24)												Package (see page 25)												
					Active Miller clamp	Current sense	Dedicated control for JFET	Desaturation protection	Enable	Error reporting with shutdown	Fault reporting	Fault reset	Over-current protection	Separate pin for logic ground	Separate sink/source outputs	Soft over-current shutdown	Two-level turn-off	Under-voltage lockout	DSO-8	DSO-8 300mil	DSO-16 WB	DSO-19	DSO-36	DIP-8	SOT23-6	Chip			
1200	1300/900	300/300	1EDI0512A	CT										✓	✓		✓	✓											
	2000/2000	165/170	1ED020I12-(B,F)2	CT	✓		✓			✓	✓	✓					✓		✓										
		1750/1750	1ED020I12-(B,F)T	CT	✓		✓			✓	✓	✓				✓		✓		✓									
	2200/2300	300/300	1EDI10I12M	CT	✓									✓	✓		✓	✓											
	4000/3500	120/115	1EDI20N12A	CT											✓	✓		✓	✓										
		125/120	1EDI20H12A	CT											✓	✓		✓	✓										
		300/300	1EDI20I12A	CT											✓	✓		✓	✓	✓									
			1EDI20I12M	CT	✓										✓			✓	✓	✓									
	4000/4000	80/80	1EDI30J12C	CT			✓		✓								✓					✓							
	5900/6200	300/300	1EDI30I12M	CT	✓										✓			✓	✓	✓									
	7500/6800	300/300	1EDI40I12A	CT											✓	✓		✓	✓	✓									
SRC/2000	460/460	1EDI20I12SV*	CT				✓	✓		✓		✓	✓	✓	✓	✓	✓				✓								
10000/9400	125/120	1EDI60H12A	CT											✓	✓		✓	✓	✓										
	300/300	1EDI60I12A	CT											✓	✓		✓	✓	✓										
600	160/240	215/140	IRS25752	J1													✓									✓			
			250/500	105/125	IR2117	J1												✓	✓							✓		✓	
					IR2118	J1													✓	✓							✓		
	IR2127	J1			✓						✓	✓				✓	✓								✓	✓			
	290/600	150/200	IR21271	J1	✓						✓	✓				✓	✓							✓					
			IR2128	J1	✓							✓	✓				✓	✓							✓	✓			
			IRS211(7,8)	J1													✓	✓							✓		✓		
	290/600	150/150	IRS2127	J1	✓						✓	✓				✓	✓							✓	✓				
IRS21271			J1	✓		✓				✓	✓				✓	✓								✓					
500	1600/3300	200/170	IR2125	J1	✓					✓	✓	✓				✓			✓										
200	160/240	215/140	IRS20752	J1													✓									✓			
100	160/240	215/140	IRS10752	J1													✓									✓			

SRC = Turn on slew rate control \*New

## Dual high-side gate driver IC

Typical connection

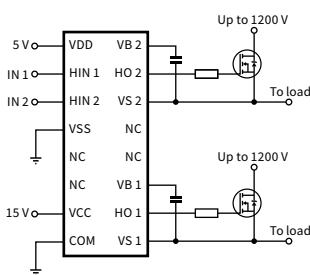

Voltage class [V]	I <sub>OH</sub> /I <sub>OL</sub> typ [mA]	Typ. prop. delay: off/on [ns]	Base PN	Technology	Features (see page 24)					Package (see page 25)
					Desaturation protection	Fault reporting	Fault reset	Separate pin for logic ground	Under-voltage lockout	DSO-36
1200	2000/2000	165/170	2ED020I12-F2	CT	✓	✓	✓	✓	✓	✓



## High-side and low-side gate driver ICs

Typical connection

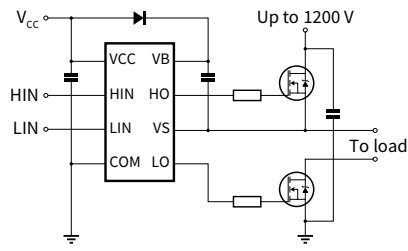

Voltage class [V]	I <sub>OH</sub> /I <sub>OL</sub> typ [mA]	Typ. prop. delay: off/on [ns]	Base PN	Technology	Features (see page 24)				Package (see page 25)			
					Integrated bootstrap diode	Separate pin for logic ground	Shutdown	Under-voltage lockout	DSO-8	DSO-14	DSO-16 WB	DIP-8
1200	2000/2500	225/280	IR2213	J1	✓	✓	✓		✓		✓	✓
700	220/350	200/220	IR7106	J1			✓	✓				
600	200/350	200/220	IR2106	J1			✓	✓			✓	
			IR21064	J1	✓		✓	✓			✓	
			IR2301	J1			✓	✓			✓	
			IR25604	J1			✓	✓				
			IRS2301	J1			✓	✓				
	210/360	150/160	IR2101	J1			✓	✓			✓	✓
			IR2102	J1			✓	✓			✓	
	250/500	105/125	IR2112	J1		✓	✓	✓		✓	✓	
			IRS2112	J1	✓	✓	✓			✓	✓	✓
	290/600	150/160	IRS2101	J1			✓	✓			✓	✓
			IRS2106	J1			✓	✓			✓	✓
		200/220	IRS21064	J1	✓		✓	✓		✓	✓	
	360/700	400/420	2EDL05I06BF	SOI	✓		✓	✓				
	1900/2300	220/180	IRS2181	J1			✓	✓			✓	✓
			IR2181	J1			✓	✓			✓	
			IR21814	J1	✓		✓	✓			✓	
			IRS21814	J1	✓		✓	✓			✓	✓
	2500/2500	94/120	IR2113	J1	✓	✓	✓			✓	✓	✓
			IR25607	J1	✓	✓	✓			✓		
		120/130	IRS2113	J1	✓	✓	✓			✓	✓	✓
4000/4000	170/170	IRS2186	J1			✓	✓			✓	✓	
		IRS21864	J1	✓		✓	✓			✓		
		IRS21867	J1			✓	✓					
500	2500/2500	94/120	IR2110	J1	✓	✓	✓			✓	✓	
		120/130	IRS2110	J1	✓	✓	✓			✓	✓	
200	290/600	150/160	IRS2005	J1			✓	✓			✓	
	1000/1000	60/60	IRS2011	J1			✓	✓			✓	
		75/80	IR2011	J1			✓	✓			✓	
	3000/3000	65/95	IR2010	J1	✓	✓	✓			✓		

### Single low-side gate driver ICs

Typical connection

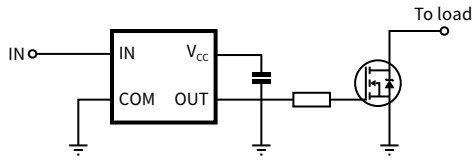

Voltage class [V]	I <sub>o+</sub> /I <sub>o-</sub> typ [mA]	Typ. prop. delay: off/on [ns]	Base PN	Technology	Current sense	Enable	Error reporting with shutdown	Fault reporting	Over-current protection	Separate sink/source outputs	Under-voltage lockout	Package (see page 25)			
					Features (see page 24)							DIP-8	SOT23-5	SOT23-6	WSON-6
25	300/550	50/50	IR44252	NI							✓	✓			
			IRS44273	NI							✓	✓			
			IR44272	NI	✓						✓	✓			
			IR44273	NI							✓	✓			
20	4000/8000	19/19	1EDN(7,8)511B**	NI	✓				✓	✓			✓		
			1EDN7512*	NI	✓				✓			✓	✓		
5	1600/3300	200/150	IR2121	NI	✓		✓	✓	✓	✓	✓				

\*New \*\*Coming soon

### Dual low-side gate driver ICs

Typical connection

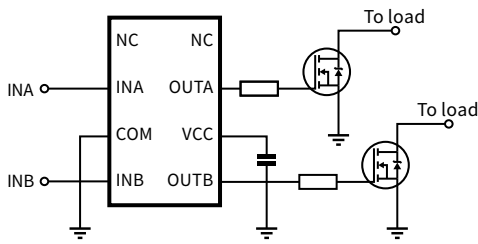

Voltage class [V]	I <sub>o+</sub> /I <sub>o-</sub> typ [mA]	Typ. prop. delay: off/on [ns]	Base PN	Technology	Enable	Under-voltage lockout	Package (see page 25)				
					Features (see page 24)		DSO-8	DIP-8	WSON-8	TSSOP-8	
25	2300/3300	50/50	IRS4426	NI			✓				
			IRS44262	NI	✓	✓					
			IRS4427	NI		✓	✓				
			IR25600	NI		✓	✓				
			IR442(6,7)	NI		✓	✓				
20	5000/5000	19/19	2EDN752(3,4)	NI	✓	✓	✓	✓	✓	✓	
			2EDN852(3,4)	NI	✓	✓	✓	✓	✓	✓	

### Complementary: Current sense ICs

Typical connection

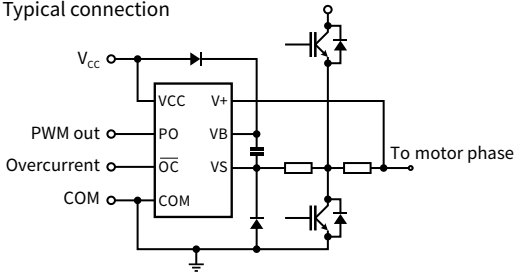

Voltage class [V]	Base PN	Technology	Current sense	Over-current protection	Separate pin for logic ground	Package (see page 25)		
			DSO-8	DSO-16 WB	DIP-8	SOT23-5		
1200	IR2277(1)	J1	✓	✓	✓	✓		
	IR2172	J1		✓		✓	✓	
600	IR2175	J1	✓	✓		✓	✓	
	IR2177(1)	J1	✓	✓	✓	✓		
	IR25750	J1		✓				✓

### Complementary: High-voltage start-up IC

Typical connection

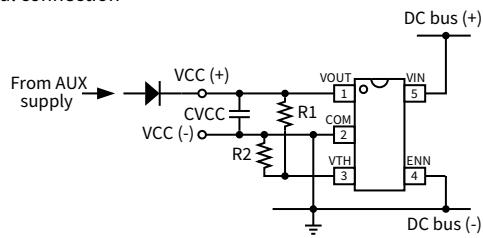

Voltage class [V]	Base PN	Technology	Enable	High-voltage start-up	Over temperature shutdown	Package (see page 25)
			SOT23-5			
480	IRS25751	J1	✓	✓	✓	✓

## Complementary: Opto-isolated solid state relays

Typical connection

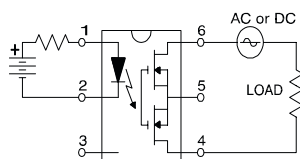

Microelectronic relays (MER) are power MOSFET or IGBT output photovoltaic relays where the output switch is controlled by radiation from a GaAlAs light emitting diode (LED) optically isolated from the output. MERs are a good choice to replace mechanical relays.

DIP-4-902	DIP-6	SM PDIP-6	DIP-8	SM DIP-8	DIP-4	SM DIP-4	DIP-10
-----------	-------	-----------	-------	----------	-------	----------	--------

Load voltage [V]	Load current [mA]	R <sub>DS(on)</sub> [Ω]	Isolation voltage [V <sub>RMS</sub> ]	Base PN	Package (see page 25)								
400	1000 AC/DC	---	3750	PVX6012	✓								
	140 AC/DC	27/7	4000	PVU414		✓	✓						
	120 AC/DC	35/9	4000	PVT412L	✓	✓							
	240 AC/DC	6/2	4000	PVT412A		✓	✓						
	140 AC/DC	27/7	4000	PVT412		✓	✓						
	120 AC/DC	35	4000	PVT422				✓	✓				
300	150 AC/DC	24	4000	PVA3354N						✓	✓		
				PVA3324N						✓	✓		
	50 AC/DC	160	4000	PVA3055N						✓	✓		
				PVA3054N						✓	✓		
250	170 AC/DC	15/4.25	4000	PVT312L		✓	✓						
	190 AC/DC	10/3	4000	PVT312		✓	✓						
	170 AC/DC	8	4000	PVT322A				✓	✓				
	170 AC/DC	10	4000	PVT322				✓	✓				
200	150 AC/DC	24	4000	PVA2352N						✓	✓		
150	550 AC/DC	0.7/0.25	4000	PVT212		✓	✓						
100	360 AC	5	1500	PVR130(0,1)									✓
	550 DC	1.5	4000	PVD1354N						✓	✓		
				PVD1352N						✓	✓		
				PVA1354N						✓	✓		
	375 AC/DC	5	4000	PVA1352N						✓	✓		
60	1500 DC	0.25	4000	PVDZ172N						✓	✓		
	1000 AC	0.5	4000	PVAZ172N						✓	✓		
	1000 AC/2000 DC	0.5/0.15	4000	PVG613*		✓	✓						
	2000 AC/4000 DC	0.1/0.035	4000	PVG612A		✓	✓						
	1000 AC/2000 DC	0.5/0.15	4000	PVG612		✓	✓						
20	2500 AC/4500 DC	0.1/0.04	4000	PVN013*		✓	✓						
	4000 AC/6000 DC	0.05/0.015	4000	PVN012A		✓	✓						
	2500 AC/4500 DC	0.1/0.04	4000	PVN012		✓	✓						

\*10 nA leakage current



### Complementary: Opto-isolated gate drivers/voltage sources

Typical connection

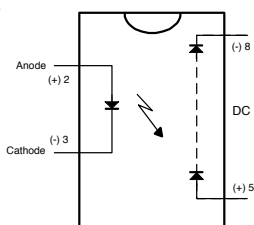

Photovoltaic isolators generate an electrically isolated DC voltage upon receipt of a DC input signal and are capable of directly driving MOSFET or IGBT gates. The output is controlled by radiation from a GaAlAs light emitting diode (LED) optically isolated from the output

DIP-8	SM DIP-8	DIP - 4	SM DIP-4
-------	----------	---------	----------

Output voltage DC [V]	Short current [ $\mu$ A]	Nominal control current (DC) [mA]	Isolation voltage [ $V_{RMS}$ ]	Base PN	Package (see page 25)			
5/10	10/5	5	5	PVI5033R	✓	✓		
3/6	2/1	5	5	PVI5013R	✓	✓		
5/10	10/5	10	10	PVI1050N	✓	✓		
5	8	10	10	PVI5080N			✓	✓
5	5	10	10	PVI5050N			✓	✓

# Features

Addressing various application requirements, Infineon delivers solutions with an assortment of features intended to optimize performance, minimize size and reduce cost. Below is a table of additional gate driver IC features available in the current portfolio.

Feature	Benefits
Active Miller clamp	Protection against inadvertent dynamic turn-on because of parasitic effects
Brake chopper	Integrated brake IGBT driver with protection
Comparator	General purpose comparator included
Current amplifier	An independent opamp for current measurement or over-current detection
Current sense	Dedicated input detects over-current events
Dedicated JFET control	Optimized to drive SiC JFET
Desaturation protection	Protects the switch (IGBT) at short circuit
Enable	Dedicated pin terminates all outputs
Error reporting with shutdown	Pin indicates fault conditions and programs shutdown time
Fault reporting	Indicates an over-current or under-voltage shutdown has occurred
Fault reset	Dedicated pin resets the DESAT-FAULT-state of the chip
High-voltage start-up	Provides easy and fast circuit start-up while enabling low circuit standby losses
Integrated bootstrap diode	Integrated bootstrap reduces BOM
Over temperature shutdown	Internal over temperature protection circuit protects the IC against excessive power loss and overheating
Over-current protection	Ensures safe application operation in case of over-current
Programmable sead time	Dead time is programmable with external resistor for flexible design
Programmable shutdown	A shutdown feature has been designed into a pin
Self-oscillating	Integrated front end oscillator
Separate pin for logic ground	Dedicated pin or logic ground for improved noise immunity
Separate sink/source outputs	Simplifies gate resistor selection, reduces BOM, and improves dV/dt control
Shoot-through protection	Functionality such as deadtime and interlock
Shutdown	Dedicated pin disables the IC outputs
Soft over-current shutdown	Dedicated pin turns off the desaturated transistor, preventing over-voltages
Two-level turn-off	Lowers VCE overshoots at turn off during short circuits or over current events
Under-voltage lockout	Ensures safe application operation by avoiding unexpected driver behavior



## Package options

Infinion offers a multitude of packages. Below is a list of gate driver IC package options which are currently available.

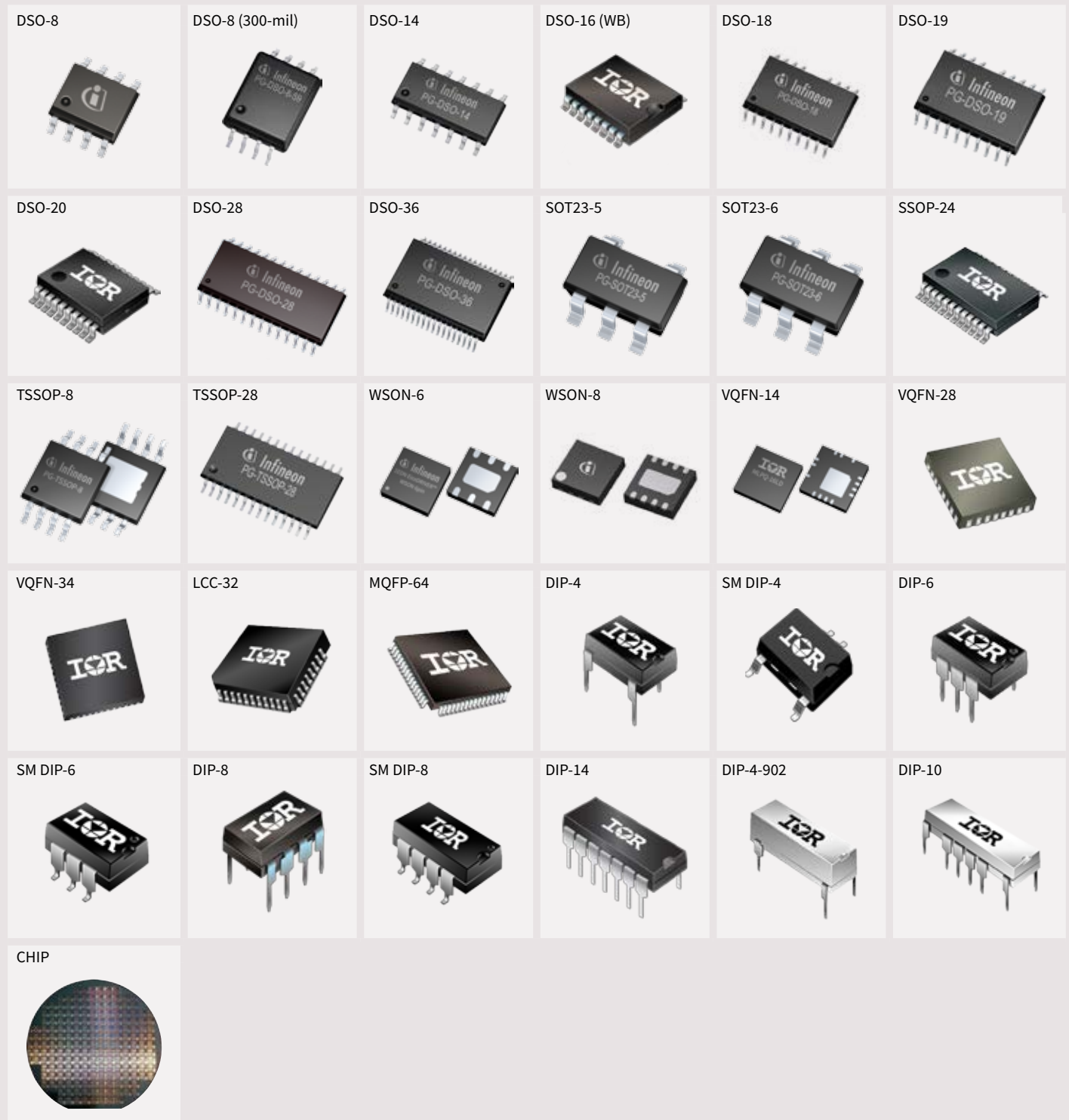

# New product highlights

The following segment features Infineon's latest gate driver IC families at a glance. Visit the family pages for more information.

## IRS2890DS 600-V gate driver IC

### 600-V half-bridge driver IC with overcurrent protection

The new 600-V half-bridge driver IC is optimized for high-voltage motor drive applications in major home appliance applications requiring rigorous standards for reliability and quality.

Designers are constantly challenged with developing compact, energy-efficient solutions while maintaining a high level of reliability and ruggedness. The IRS2890DS is tailored for motor drive applications requiring over current protection and best-in-class default reporting accuracy in a small form-factor with high-voltage IC process to realize a compact, efficient and robust monolithic construction while integrating several features.

The IRS2890DS achieves high-power density by integrating the bootstrap FET, under-voltage (UVLO) protection, shoot-through protection, overcurrent protection, fault reporting, and fault clear function. The overcurrent protection feature has an internal threshold of  $\pm 5\%$  for accurate reporting. Additionally, the IRS2890DS has  $V_s$  operational logic of  $-8\text{ V}$  and is tolerant to negative transient voltages. The IRS28990DS is offered in fourteen-pin SOIC and requires the use of less pins than comparable parts on the market.

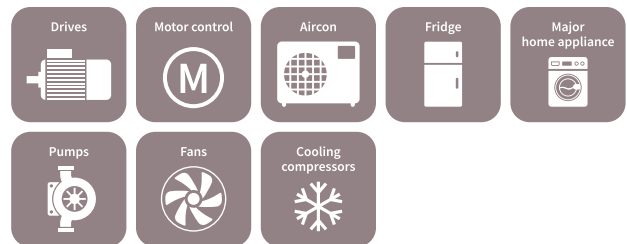
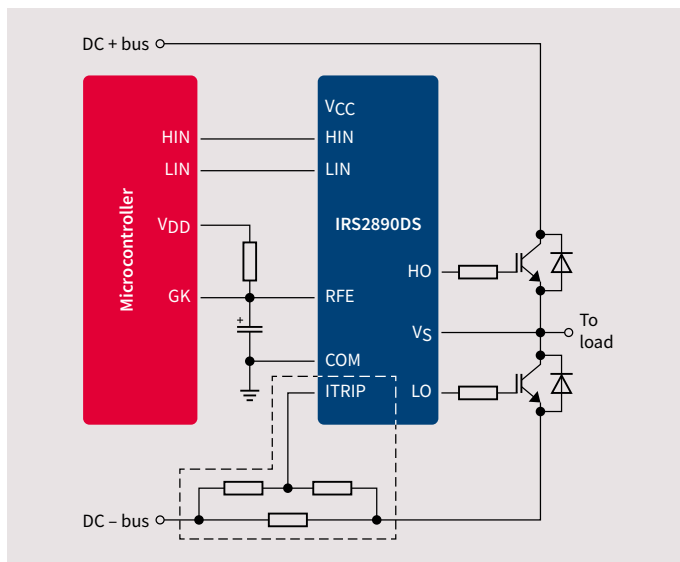

For more information visit [www.infineon.com/IRS2890DS](http://www.infineon.com/IRS2890DS)

## IRS200x 200-V gate driver family

### Now including IRS2008

Infinion offers 200-V half-bridge and high- and low-side driver ICs tailored for low-voltage (24 V, 36 V, and 48 V) and mid-voltage (60 V, 80 V, and 100 V) motor drive applications.

The IRS200x family utilizes our advanced high-voltage IC process to realize a compact, efficient, and robust monolithic construction.

The IRS200x family consists of seven devices with a typical output sink current of 600 mA and typical output source current of 290 mA. The 200 V devices are 3.3, 5 and 15 V logic compatible.  $V_{CC}$  under-voltage lockout (UVLO) protection is a standard feature provided across the family while IRS2008 and IRS2005 also include  $V_{BS}$  UVLO protection. Additionally,

the IRS2008 has  $V_s$  operational logic of -8 V. The IRS2008, IRS2004, and IRS2003 include integrated deadtime and shoot-through protection. The 200 V devices feature low quiescent currents. IRS2008 and IRS2004 also features a shutdown input pin.

The 200 V devices are offered in eight-pin SOIC, eight-pin DIP or fourteen-pin 4 x 4 mm MLPQ packages with various logic input options and standard pin-out configurations for high design flexibility and fast time-to-market.

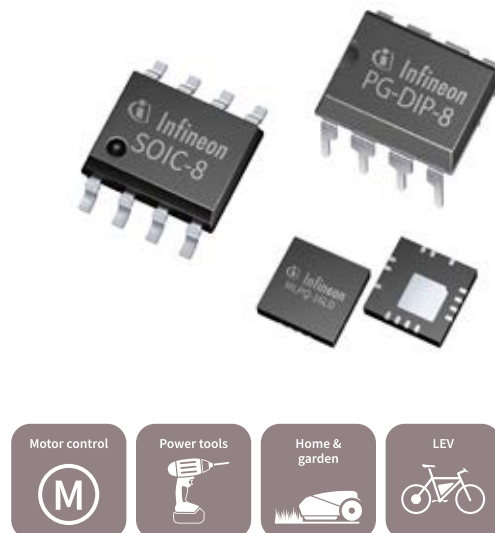
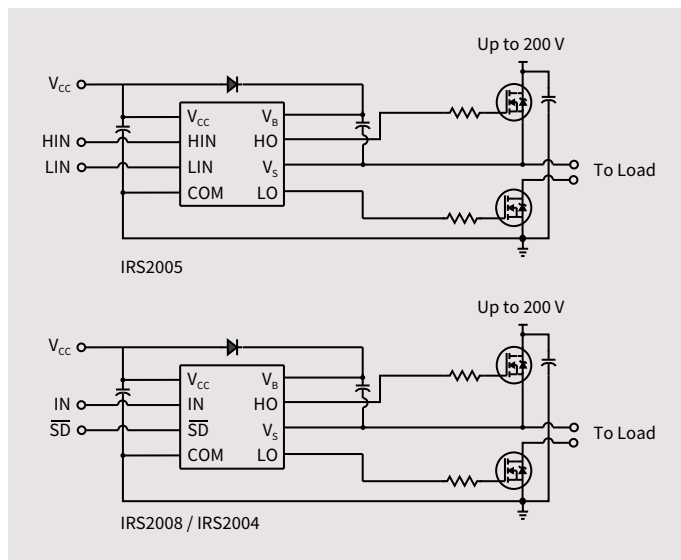

Motor control



Power tools



Home & garden



LEV



For more information visit [www.infineon.com/200VHVIC](http://www.infineon.com/200VHVIC)

## 2EDL EiceDRIVER™ compact

### 600-V half-bridge gate driver ICs with integrated bootstrap diode

The new 2EDL EiceDRIVER™ Compact high-voltage gate driver family meets the ever-growing need for higher application efficiency and smaller form factors in consumer electronics and home appliances. It is optimized for the switching behavior and power losses of today's power supplies using IGBT and MOSFETs with dramatically reduced gate charges such as the latest generation of Infineon's CoolMOS™. With a monolithically integrated ultrafast low-ohmic bootstrap diode, the 2EDL Compact sets the benchmark for driver ICs needed in applications with more than 2 A output currents.

The 2EDL Compact family comprises seven 600 V drivers with output currents of 0.5 A and 2.3 A in DSO-8 and DSO-14 150 mil packages for applications based on IGBT or MOSFET switches:

- › The 2EDL05I06BF in DSO-8, optimized for IGBTs, comes without interlock or dead time. It is ideal for switched reluctance motor drives and two-transistor forward switched-mode power supply topologies.
- › The 2EDL05I06PF in DSO-8 and the 2EDL05I06PJ in DSO-14 are optimized for IGBTs and include interlock and dead time. They are recommended for applications such as fans, pumps, major home appliances, power tools, and general purpose inverters. The DSO-14 version is recommended for industrial applications with higher creepage distance requirements.
- › The 2EDL05N06PF in DSO-8 and the 2EDL05N06PJ in DSO-14 boast the same features as the IGBT driver versions and an under-voltage lockout adapted for MOSFETs. They are recommended for servers and telecommunications equipment, low-voltage drives, e-bikes, battery chargers, and half-bridge-based switched-mode power supply applications.
- › The 2EDL23I06PJ and 2EDL23N06PJ are 2.3 A half-bridge driver ICs in DSO-14 with interlock, dead time, fault enable, and overcurrent protection. The 2EDL23I06PJ for IGBTs is ideal for applications such as multi-oven IH cookers, fans, pumps, and drives. The 2EDL23N06PJ for MOSFETs is best suited for switched-mode power supplies, servers and telecommunications equipment, e-scooters, forklifts, and battery chargers.

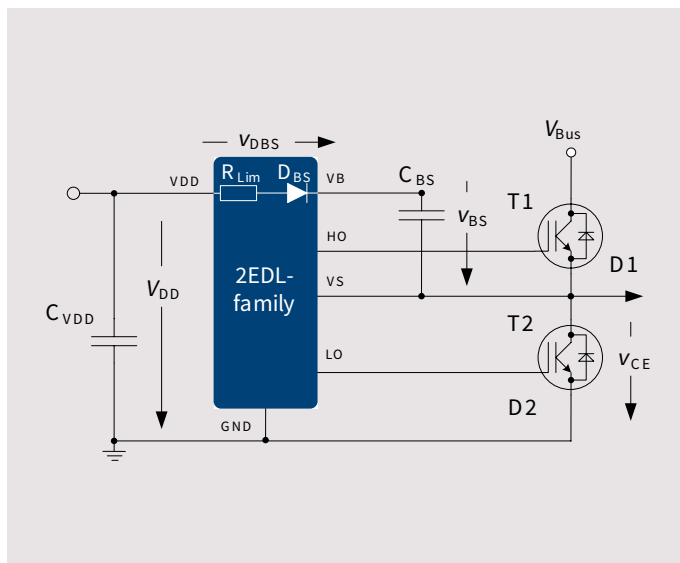

ED-C  
Compact

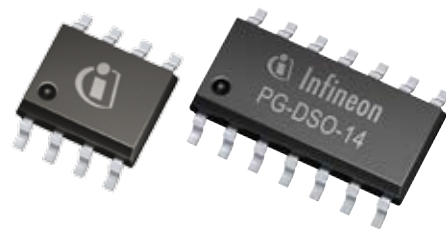

For more information visit [www.infineon.com/eicedriver-compact](http://www.infineon.com/eicedriver-compact)

## 1EDI20I12SV EiceDRIVER™

### 1200-V single-channel driver IC with dynamic slew-rate control

The new 1EDI20I12SV EiceDRIVER™ serves the latest generation of highly efficient low-EMI electric drive systems with a variety of advanced features. It is the first driver on the market with dynamic slew-rate control (SRC) that allows on-the-fly  $dV/dT$  control of electric drives through precise gate current control, providing for the best tradeoff between minimum power dissipation and minimum EMI depending on operating conditions such as high and low load.

The driver also includes desaturation protection for IGBTs and overcurrent protection for sense IGBTs via the fault status output pin. Two ready-state output pins indicate proper driver power supply and normal operation. Two-level turn-off with adjustable timing and voltage protects against excessive overvoltage in case of the IGBT operating at overcurrent or a short circuit. To turn on the IGBT, the driver works as an adjustable current source in conjunction with an external PMOS transistors and a sense resistor. To turn off the IGBT, the driver uses a 2 A MOSFET output stage.

The 1EDI20I12SV is tailored for industrial drive applications using 1200 V power modules for currents up to 900 A, such as the EconoDUAL™ 3 (up to 600 A). It is a single-channel IGBT driver IC based on Infineon's coreless transformer technology.

The driver meets today's long-term stability requirements for industrial applications. It is offered in a DSO-36 package with a package width of 300 mil. It is RoHS compliant, green, and halogen-free.

#### Features

- › 1200- V single-channel IGBT driver IC
- › Unique: precise dynamic gate current control
- › Unique: selective short circuit protection for 3-level inverters
- › Overcurrent protection for sense IGBTs and conventional IGBTs
- › Protection: DESAT, soft turn-off or two-level turn-off

#### Benefits

- › Low EMI during low load conditions and high efficiency during high load conditions
- › Reduction or elimination of  $dV/dT$  filter

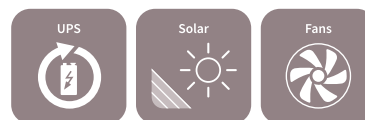
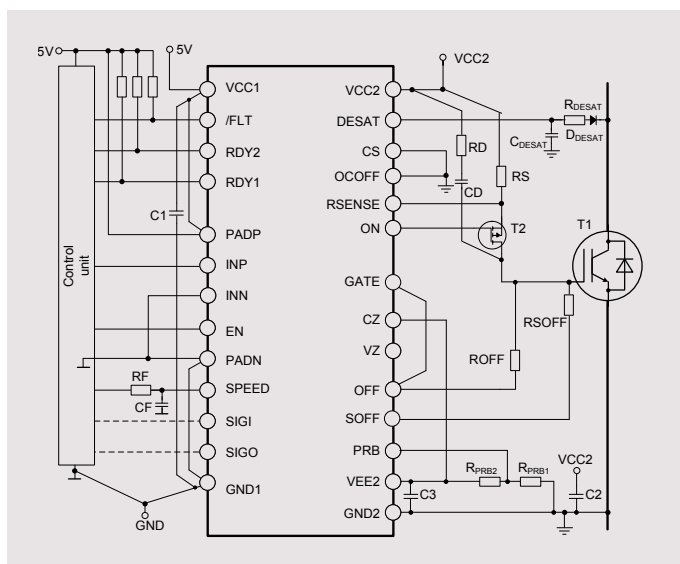

## 1EDI EiceDRIVER™ compact 150-mil and 300-mil

### 1200-V galvanically isolated single-channel wide body gate driver IC family

Our new 1EDI EiceDRIVER™ Compact family complements our extensive range of high-voltage driver ICs for a market that demands easy-to-use drivers with a small footprint for quick design-in cycles. The driver family is based on Infineon's coreless transformer technology, enabling a benchmark-setting minimum common mode transient immunity (CMTI) of 100 kV/μs with drive strengths of up to 6 A. They are ideal for IGBT-based applications such as photovoltaic string inverters, charge stations for electric vehicles, industrial drives, welding equipment, induction heating appliances and power supplies for servers and telecommunication systems

#### Features

- › Single-channel isolated high-voltage gate driver IC
- › 12 V input-to-output isolation voltage
- › Drives high-voltage power MOSFETs and IGBTs
- › Up to 6 A minimum peak rail-to-rail output
- › Separate source and sink outputs or active Miller clamp
- › DSO-8 300-mil-wide body package option with 8-mm creepage distance

#### Benefits

- › Best-in-class common mode transient immunity (CMTI): 100 kV/μs
- › Wide input operating range (3...17 V)
- › No voltage/signal adaptation between μC and driver necessary

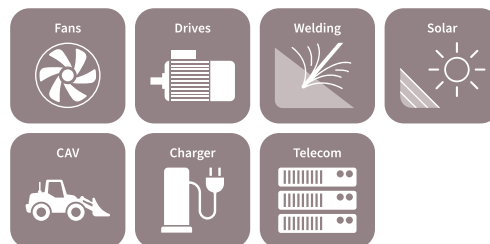
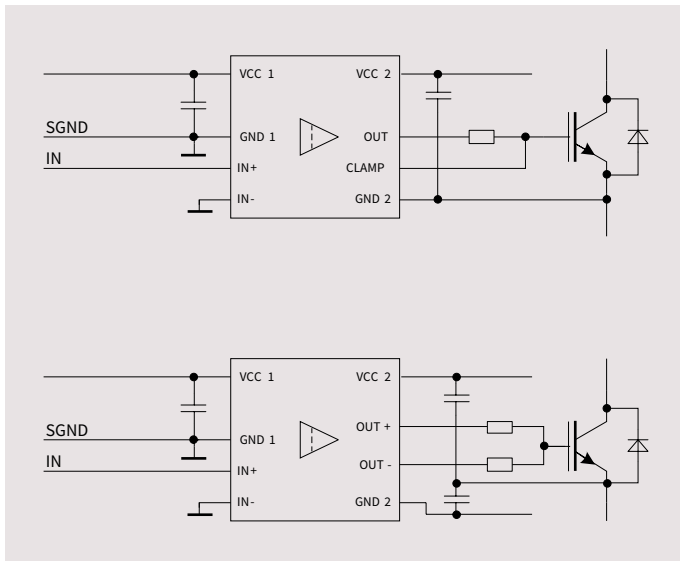

For more information visit [www.infineon.com/300mill](http://www.infineon.com/300mill) and [www.infineon.com/eicedriver-compact](http://www.infineon.com/eicedriver-compact)

## 1EDN and 2EDN EiceDRIVER™ families

### Rugged, cool and fast, 1-channel low-side 4/8 A gate driver ICs

1-channel (1EDN) and 2-channel (2EDN) MOSFET gate driver ICs are the crucial link between control ICs and powerful MOSFET and GaN switching devices. Gate driver ICs enable high system level efficiencies, excellent power density and consistent system robustness.

#### Fast, precise, strong and compatible

- > Highly efficient SMPS enabled by 5 ns short slew rates and  $\pm 5$  ns propagation delay precision for fast MOSFET and GaN switching
- > Separate source and sink outputs simplify the application design
- > Industry standard packages and pin-out ease system design upgrades

#### The new reference in ruggedness and low power dissipation

- > -10 V robustness of control and enable inputs provides crucial safety margin when driving pulse transformers
- > 5 A reverse output current robustness eliminates the need for Schottky switching diodes when driving MOSFETs in T0-220 and T0-247 packages
- > Cool driver ICs from true rail-to-rail low impedance output stages
- > 4 V and 8 V UVLO (under-voltage lockout) options for instant MOSFET protection during start-up and under abnormal conditions

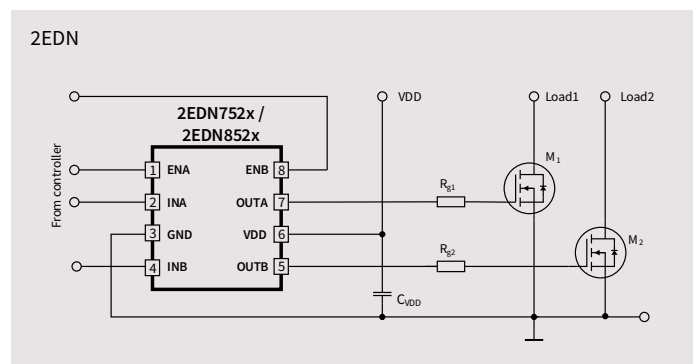
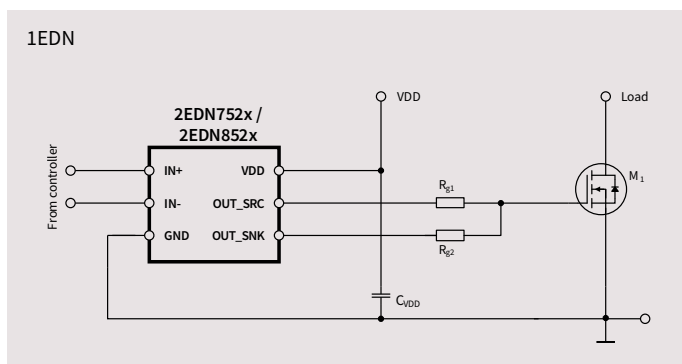
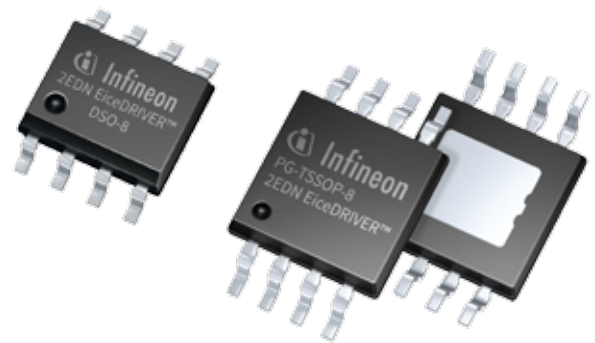
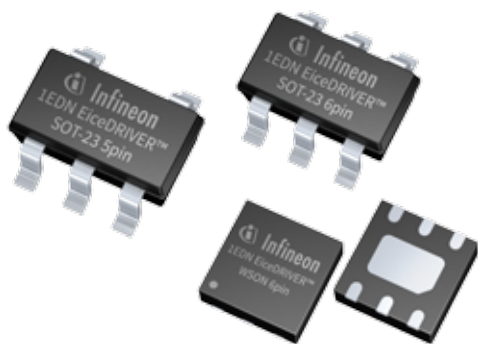

For more information visit [www.infineon.com/1edn](http://www.infineon.com/1edn)

For more information visit [www.infineon.com/2edn](http://www.infineon.com/2edn)

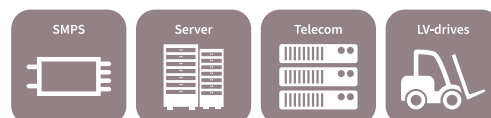
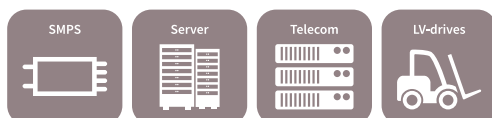

# Infineon's powerful gate driver IC support

## Useful links and helpful tools

### Gate driver IC selection tool

To simplify the gate driver selection process, Infineon offers an online easy-to-use gate driver selection tool. By selecting a few key parameters, the tool quickly guides you in finding the right driver for your application.

<p><b>Gate driver selection criteria</b></p> <ol style="list-style-type: none"> <li>1 Driver current</li> <li>2 Voltage class</li> <li>3 Switching frequency</li> <li>4 Driver configuration</li> <li>5 Isolation requirement</li> <li>6 Qualification level</li> <li>7 Package</li> </ol>	<p>or</p>	<p><b>Driver selection based on switch criteria</b></p> <ol style="list-style-type: none"> <li>1 Switch type</li> <li>2 Voltage class</li> <li>3 Gate resistance</li> </ol>
--	-----------	---

**Start exploring today!**  
Visit: [www.infineon.com/driver-finder](http://www.infineon.com/driver-finder)



### Infineon Designer



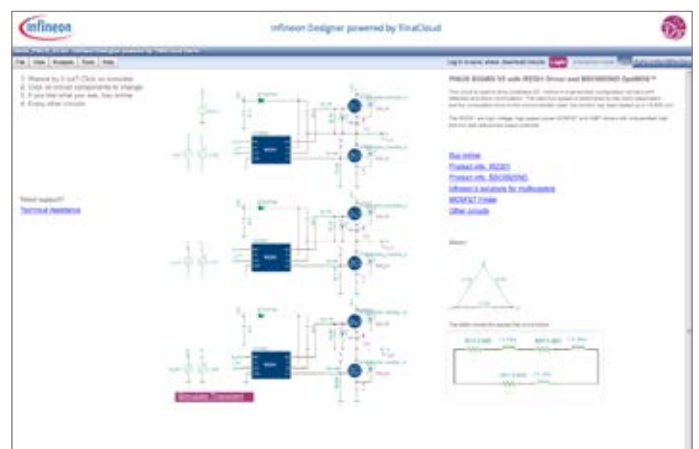











Select gate driver prototypes are available on [www.infineon.com/ifxdesigner](http://www.infineon.com/ifxdesigner). Infineon Designer is an online prototyping engine combining analog and digital simulation functionalities in an Internet application. Requiring a web browser only, it is a perfect match for supporting customers in selecting the right product for a defined application.





## Gate driver IC evaluation boards

EiceDRIVER™ evaluation boards are available on [www.infineon.com/tool](http://www.infineon.com/tool). The boards enable fast evaluation, prototyping and system design by demonstrating key characteristics and benefits of Infineon gate driver ICs.

Evaluation board	 <p><b>EVAL-6EDL04I06PT</b> Single EiceDRIVER™ with six 600 V Trenchstop™ Infineon IGBTs in full-bridge configuration</p>	 <p><b>EVAL-6EDL04N02PR</b> Single EiceDRIVER™ with six 80 V OptiMOS™ Infineon MOSFETs in full-bridge configuration</p>	 <p><b>EVAL-2EDL23I06PJ</b> Single EiceDRIVER™ with two 600 V Infineon IGBTs in half-bridge configuration</p>	 <p><b>EVAL-2EDL23N06PJ</b> Single EiceDRIVER™ with two 600 V Infineon COOLMOS™ MOSFETs in half-bridge configuration</p>
Featured gate driver	 <p><b>6EDL04I06PT</b> LS-SOI 600 V three-phase gate driver IC with ultra-fast bootstrap diode and integrated protective features (interlock, over-current protection, fault reporting, and under-voltage lock out)</p>	 <p><b>6EDL04N02PR</b> LS-SOI 200 V three-phase gate driver IC with ultra-fast bootstrap diode and integrated protective features (interlock, over-current protection, fault reporting, and under-voltage lock out)</p>	 <p><b>2EDL23I06PJ</b> LS-SOI 600 V half-bridge gate driver IC with ultra-fast bootstrap diode and integrated protective features (interlock, over-current protection, fault reporting, and under-voltage lockout)</p>	 <p><b>2EDL23N06PJ</b> LS-SOI 600 V half-bridge gate driver IC with ultra-fast bootstrap diode and integrated protective features (interlock, over-current protection, fault reporting, and under-voltage lockout)</p>
Evaluation board	 <p><b>EVAL-1EDI60I12AF</b> Two EiceDRIVER™s with two 600 V TRENCHSTOP™ Infineon IGBTs in half-bridge configuration</p>	 <p><b>EVAL-1ED020I12-BT</b> Two EiceDRIVER™s with two 1200 V Infineon IGBTs in half-bridge configuration</p>	 <p><b>EVAL-1ED020I12-B2</b> Two EiceDRIVER™s with two 1200 V Infineon IGBT modules</p>	
Featured gate driver	 <p><b>1EDI60I12AF</b> Galvanically isolated CT 1200 V single-channel gate driver IC for high-voltage power IGBTs</p>	 <p><b>1ED020I12-BT</b> Galvanically isolated CT 1200 V single-channel gate driver IC for high-voltage power IGBTs with integrated protective features (desaturation detection, two-level turn-off, active Miller clamping)</p>	 <p><b>1ED020I12-B2</b> Galvanically isolated CT 1200 V single-channel gate driver IC for high-voltage power IGBTs with integrated protective features (desaturation detection, two-level turn-off, active Miller clamping)</p>	

Contact your local Infineon sales team for evaluation board availability information.

## Gate driver IC chips for multi-chip packages

Infineon offers gate driver IC chips to address the on-going trend of integrating the driver, power stages, controllers and other components into a smaller, more efficient single package.

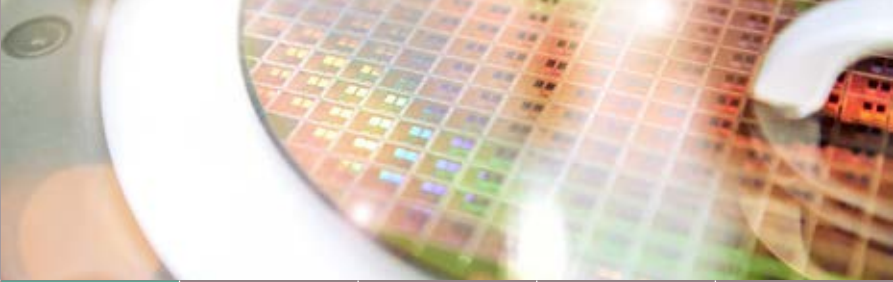
					Technology	Current amplifier	Current sense	Enable	Fault reporting	Integrated bootstrap diode	Over-current protection	Programmable shutdown	Self-oscillating	Separate pin for logic ground	Shoot-through protection	Shutdown	Under-voltage lockout	Chip		
Driver configuration	Voltage class [V]	I <sub>O+</sub> /I <sub>O-</sub> typ [mA]	Typ. prop. delay: off/on [ns]	Base PN	Features (see page 24)															
Single high-side	600	250/500	105/250	IR2117	J1													✓	✓	
			150/200	IR2127	J1	✓		✓	✓								✓	✓	✓	
		290/600	105/125	IRS211(7,8)	J1	✓		✓	✓									✓	✓	✓
			150/150	IRS2127	J1	✓		✓	✓									✓	✓	✓
			150/150	IRS2127	J1	✓		✓	✓									✓	✓	✓
High-side and low-side	1200	2000/2500	225/280	IR2213	J1									✓			✓	✓		
	600	210/360	150/160	IR2101	J1												✓	✓		
			130/135	IRS2112	J1									✓		✓	✓	✓		
		290/600	150/160	IRS2101	J1												✓	✓	✓	
			200/220	IRS2106	J1													✓	✓	
			1900/2300	220/180	IRS2181	J1											✓	✓	✓	
		2500/2500	94/120	IR2113	J1										✓			✓	✓	
			120/130	IRS2113	J1										✓		✓	✓	✓	
	4000/4000	170/170	IRS2186	J1													✓	✓		
	500	2500/2500	120/130	IRS2110	J1									✓			✓	✓		
	200	1000/1000	60/60	IRS2011	J1													✓	✓	
		3000/3000	65/95	IR2010	J1									✓				✓	✓	
Half-bridge	1200	180/260	na	IR21531	J1						✓	✓		✓	✓	✓	✓			
				IRS2153(1)D	J1						✓	✓		✓	✓	✓	✓			
	600	150/150	150/150	IRS2304	J1											✓	✓	✓		
			150/680	IRS2103	J1											✓	✓	✓		
		290/600	150/750	IRS2104	J1											✓	✓	✓		
			150/750	IRS2111	J1											✓	✓	✓		
			200/220	IRS2108	J1											✓	✓	✓		
		200/750	IRS2308	J1												✓	✓	✓		
			IRS2109	J1												✓	✓	✓		
	1900/2300	220/180	IRS2183	J1												✓	✓	✓		
		270/680	IRS2184	J1												✓	✓	✓		
Three-phase	1200	250/500	700/750	IR2233	J1	✓			✓	✓			✓			✓	✓	✓		
	600	165/375	490/530	6ED003L06-F2	SOI			✓	✓	✓			✓				✓	✓		
				6EDL04I06(N,P)	SOI			✓	✓	✓	✓			✓			✓	✓		
			530/530	6EDL04N06P	SOI			✓	✓	✓	✓			✓			✓	✓		
		200/350	400/425	IR2136	J1			✓	✓		✓			✓			✓	✓		
				IR21363	J1			✓	✓		✓			✓			✓	✓		
			IR21368	J1			✓	✓		✓			✓			✓	✓			
			530/500	IR21364	J1			✓	✓		✓			✓			✓	✓		
	530/530	IRS2336D	J1			✓	✓	✓	✓			✓			✓	✓				
		IRS23364D	J1			✓	✓	✓	✓			✓			✓	✓				
250/500	425/675	IR213(0,2)	J1	✓			✓		✓			✓			✓	✓				
		700/750	IR2135	J1	✓			✓		✓			✓		✓	✓				



# Where to buy

Infineon distribution partners and sales offices:

[www.infineon.com/WhereToBuy](http://www.infineon.com/WhereToBuy)

# Service hotline

Infineon offers its toll-free 0800/4001 service hotline as one central number, available 24/7 in English, Mandarin and German.

- > Germany ..... 0800 951 951 951 (German/English)
- > China, mainland ..... 4001 200 951 (Mandarin/English)
- > India ..... 000 800 4402 951 (English)
- > USA ..... 1-866 951 9519 (English/German)
- > Other countries ..... 00\* 800 951 951 951 (English/German)
- > Direct access ..... +49 89 234-0 (interconnection fee, German/English)

\* Please note: Some countries may require you to dial a code other than "00" to access this international number.  
Please visit [www.infineon.com/service](http://www.infineon.com/service) for your country!



Mobile product catalog

Mobile app for iOS and Android.

[www.infineon.com](http://www.infineon.com)

Published by  
Infineon Technologies AG  
81726 Munich, Germany

© 2017 Infineon Technologies AG.  
All rights reserved.

Order number: B159-I0446-V1-7600-NA-EC-P  
Date: 03 / 2017

#### Please note!

THIS DOCUMENT IS FOR INFORMATION PURPOSES ONLY AND ANY INFORMATION GIVEN HEREIN SHALL IN NO EVENT BE REGARDED AS A WARRANTY, GUARANTEE OR DESCRIPTION OF ANY FUNCTIONALITY, CONDITIONS AND/OR QUALITY OF OUR PRODUCTS OR ANY SUITABILITY FOR A PARTICULAR PURPOSE. WITH REGARD TO THE TECHNICAL SPECIFICATIONS OF OUR PRODUCTS, WE KINDLY ASK YOU TO REFER TO THE RELEVANT PRODUCT DATA SHEETS PROVIDED BY US. OUR CUSTOMERS AND THEIR TECHNICAL DEPARTMENTS ARE REQUIRED TO EVALUATE THE SUITABILITY OF OUR PRODUCTS FOR THE INTENDED APPLICATION.

WE RESERVE THE RIGHT TO CHANGE THIS DOCUMENT AND/OR THE INFORMATION GIVEN HEREIN AT ANY TIME.

#### Additional information

For further information on technologies, our products, the application of our products, delivery terms and conditions and/or prices, please contact your nearest Infineon Technologies office ([www.infineon.com](http://www.infineon.com)).

#### Warnings

Due to technical requirements, our products may contain dangerous substances. For information on the types in question, please contact your nearest Infineon Technologies office.

Except as otherwise explicitly approved by us in a written document signed by authorized representatives of Infineon Technologies, our products may not be used in any life-endangering applications, including but not limited to medical, nuclear, military, life-critical or any other applications where a failure of the product or any consequences of the use thereof can result in personal injury.