

# Preliminary Datasheet

## SGP30

### Important Note:

- All specifications are preliminary and are subject to change without prior notice.
- Characterization and qualification of this product is ongoing.

# SGP30

## Sensirion Gas Platform *Preliminary Datasheet*

- MEMS metal-oxide gas sensor for measuring volatile organic compounds (VOCs)
- Outstanding long-term stability
- I<sup>2</sup>C interface with TVOC and CO<sub>2</sub>eq output signals
- Very small 6-pin DFN package: 2.45 x 2.45 x 0.9 mm<sup>3</sup>
- Low power consumption: 48 mA at 1.8V
- Tape and reel packaged, reflow solderable



### Product Summary

The SGP30 is a digital multipixel gas sensor designed for easy integration into air purifier, demand-controlled ventilation, and IoT applications. Sensirion's CMOSens<sup>®</sup> technology offers a complete sensor system on a single chip featuring a digital I<sup>2</sup>C interface, a temperature controlled micro hotplate, and two preprocessed indoor air quality signals. As the first metal-oxide gas sensor featuring multiple sensing elements on one chip, the SGP30 provides more detailed information about the air quality.

The sensing element features an unmatched robustness against contaminating gases present in real-world applications enabling a unique long-term stability and low drift. The very small 2.45 x 2.45 x 0.9 mm<sup>3</sup> DFN package enables applications in limited spaces. Sensirion's state-of-the-art production process guarantees high reproducibility and reliability. Tape and reel packaging, together with suitability for standard SMD assembly processes make the SGP30 predestined for high-volume applications.

### Block Diagram

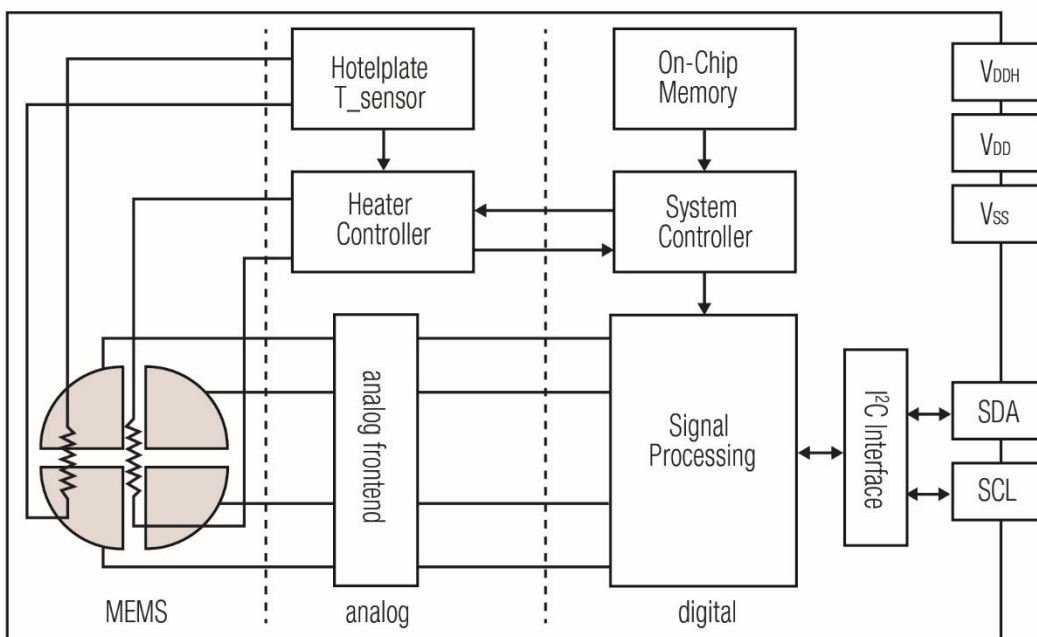

**Figure 1** Functional block diagram of the SGP30.

# 1 Sensor Performance

## 1.1 Gas Sensing Performance

Parameter	Signal	Values	Comments
Measurement range	Ethanol signal	0 ppm to 1000 ppm	
	H <sub>2</sub> signal	0 ppm to 1000 ppm	
Specified range	Ethanol signal	0.3 ppm to 30 ppm	The specifications below are defined for this measurement range <sup>1</sup> .
	H <sub>2</sub> signal	0.5 ppm to 10 ppm	
Accuracy	Ethanol signal	see <b>Figure 2</b> typ.: 15% of meas. value	Accuracy of the concentration <i>c</i> determined by $\ln\left(\frac{c}{c_{ref}}\right) = \frac{(s_{ref} - s_{out})}{a}$ <i>a</i> = 512 <i>s<sub>out</sub></i> : EthOH/H <sub>2</sub> signal output at concentration <i>c</i> <i>s<sub>ref</sub></i> : EthOH/H <sub>2</sub> signal output at 0.5 ppm H <sub>2</sub> <i>C<sub>ref</sub></i> = 0.3 ppm
	H <sub>2</sub> signal	see <b>Figure 3</b> typ.: 10% of meas. value	<i>C<sub>ref</sub></i> = 0.5 ppm
Long-term drift <sup>2</sup>	Ethanol signal	see <b>Figure 4</b> typ.: 1.3% of meas. value	Change of accuracy over time: Siloxane accelerated lifetime test <sup>3</sup>
	H <sub>2</sub> signal	see <b>Figure 5</b> typ.: 1.3% of meas. value	
Resolution	Ethanol signal	0.2 % of meas. value	Resolution of Ethanol and H <sub>2</sub> signal outputs in relative change of the measured concentration
	H <sub>2</sub> signal		
Sampling frequency	Ethanol signal	Max. 5 Hz	Compare with measurement duration in <b>Table 9</b>
	H <sub>2</sub> signal		

**Table 1** Gas sensing performance. Specifications are at 25°C, 50% RH and typical VDD. The sensors have been operated for at least 24h before all characterizations.

### Accuracy Ethanol signal

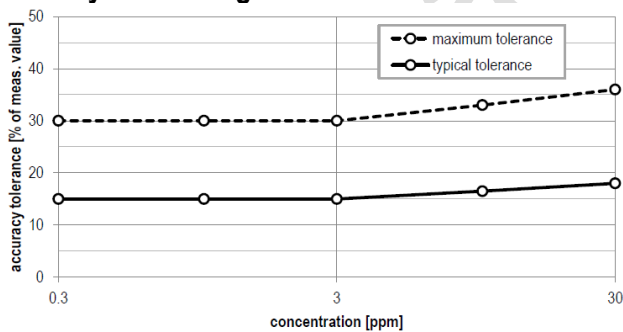

**Figure 2** Typical and maximum accuracy tolerance in % of measured value at 25°C, 50% RH and typical VDD. The sensors have been operated for at least 24h before all characterizations.

### Accuracy H<sub>2</sub> signal

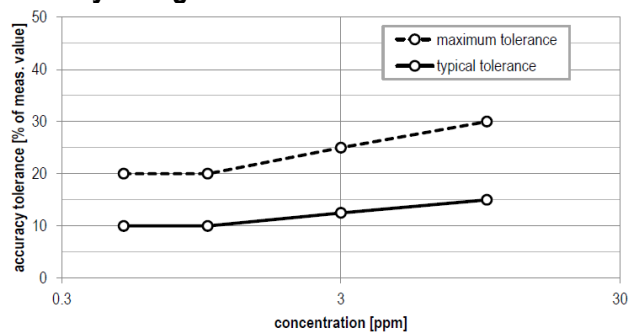

**Figure 3** Typical and maximum accuracy tolerance in % of measured value at 25°C, 50% RH and typical VDD. The sensors have been operated for at least 24h before all characterizations.

<sup>1</sup> ppm: parts per million. 1 ppm = 1000 ppb (parts per billion)

<sup>2</sup> The long-term drift is stated as change of accuracy per year of operation.

<sup>3</sup> Test conditions: operation in 250 ppm Decamethylcyclopentasiloxane (D5) for 200h simulating 10 years of operation in an indoor environment.

### Long-term drift Ethanol signal

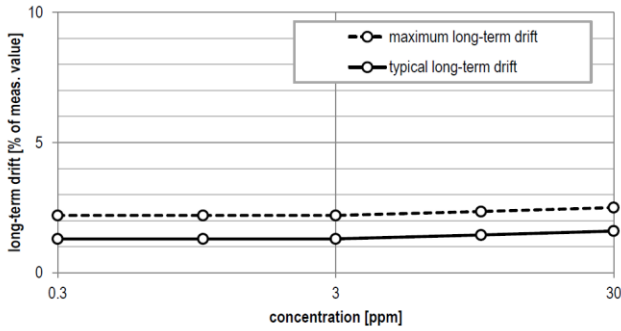

**Figure 4** Typical and maximum long-term drift in % of measured value at 25°C, 50% RH and typical VDD. The sensors have been operated for at least 24h before all characterizations.

### Long-term drift H<sub>2</sub> signal

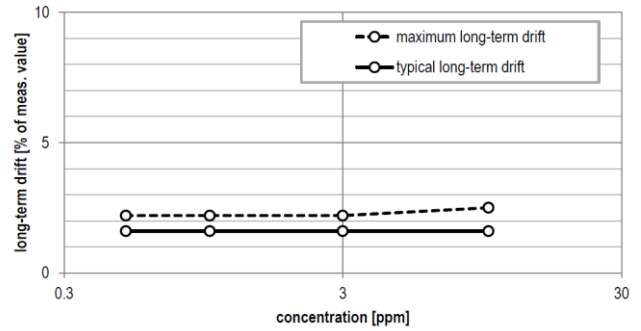
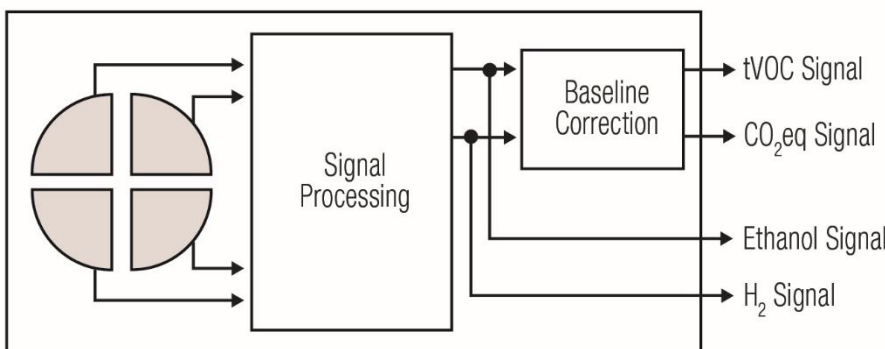

**Figure 5** Typical and maximum long-term drift in % of measured value at 25°C, 50% RH and typical VDD. The sensors have been operated for at least 24h before all characterizations.

## 1.2 Air Quality Signals

Parameter	Signal	Values		Comments
Output range	TVOC signal	0 ppb to 60000 ppb		Maximum possible output range. The gas sensing performance is specified for the measurement range as defined in <b>Table 1</b>
	CO <sub>2</sub> eq signal	400 ppm to 60000 ppm		
Resolution	TVOC signal	0 ppb - 2008 ppb	1 ppb	
		2008 ppb - 11110 ppb	6 ppb	
		11110 ppb - 60000 ppb	32 ppb	
	CO <sub>2</sub> eq signal	400 ppm - 1479 ppm	1 ppm	
		1479 ppm - 5144 ppm	3 ppm	
		5144 ppm - 17597 ppm	9 ppm	
		17597 ppm - 60000 ppm	31 ppm	
Sampling frequency	TVOC signal	1 Hz		
	CO <sub>2</sub> eq signal	1 Hz		

**Table 2** Air quality signal specifications.



**Figure 6** Simplified version of the functional block diagram (compare **Figure 1** Functional block diagram of the SGP30.) showing the signal paths of the SGP30.

## 1.3 Recommended Operating Conditions

The sensor shows best performance when operated within recommended normal temperature and humidity range of 5 – 55 °C and 25 –75 %RH, respectively. Long-term exposure to conditions outside normal range, especially at high humidity, may temporarily affect the sensor performance. Prolonged exposure to extreme conditions may accelerate aging. To ensure stable operation of the gas sensor, the conditions described in the document *SGP Handling and Assembly Instructions*

regarding exposure to exceptionally high concentrations of some organic or inorganic compounds have to be met, particularly during operation. Please also refer to the *Design-in Guide* for optimal integration of the SGP30.

## 2 Electrical Specifications

Parameter	Min.	Typ.	Max.	Unit	Comments
Supply voltage $V_{DD}$	1.62	1.8	1.98	V	Minimal voltage must be guaranteed also for the maximum supply current specified in this table.
Hotplate supply voltage $V_{DDH}$	1.62	1.8	1.98	V	
Supply current during measurements		48.2		mA	A 20% higher current is drawn during 5ms on $V_{DDH}$ , after issuing the "Measure" command (see 6.2).
Sleep current		2	10	$\mu$ A	
LOW-level input voltage	-0.5		$0.3 \cdot V_{DD}$	V	
HIGH-level input voltage	$0.7 \cdot V_{DD}$		$V_{DD} + 0.5$	V	
Vhys hysteresis of Schmitt trigger inputs			$0.05 \cdot V_{DD}$	V	
LOW-level output voltage			$0.2 \cdot V_{DD}$	V	(open-drain) at 2mA sink current
Communication	Digital 2-wire interface, I <sup>2</sup> C fast mode.				

**Table 3** Electrical specifications. Specifications are at 25°C and typical  $V_{DD}$ .

## 3 Interface Specifications

The SGP30 comes in a 6-pin DFN package, see **Table 4**.

Pin	Name	Comments
1	$V_{DD}$	Supply voltage
2	$V_{SS}$	Ground
3	SDA	Serial data, bidirectional
4	R	Connect to ground (no electrical function)
5	$V_{DDH}$	Supply voltage, hotplate
6	SCL	Serial clock, bidirectional

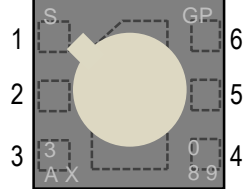

**Table 4** Pin assignment (transparent top view). Dashed lines are only visible from the bottom.

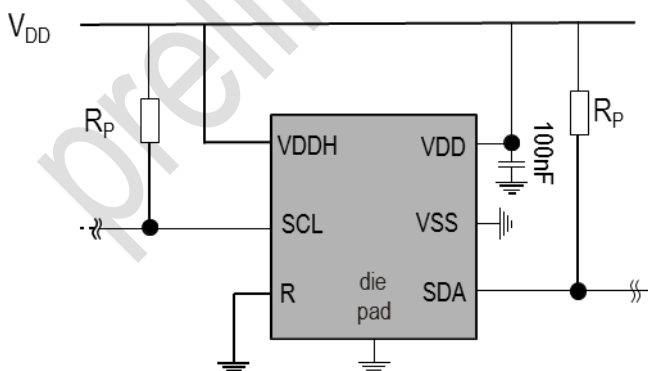

**Figure 7** Typical application circuit (for better clarity in the image, the positioning of the pins does not reflect the positions on the real sensor).

The electrical specifications of the SGP30 are shown in **Table 3**. The power supply pins must be decoupled with a 100 nF capacitor that shall be placed as close as possible to pin VDD – see **Figure 7**. The required decoupling depends on the power supply network connected to the sensor. We also recommend VDD and VDDH pins to be shorted.

SCL is used to synchronize the communication between the microcontroller and the sensor. The SDA pin is used to transfer data to and from the sensor. For safe communication, the timing specifications defined in the I<sup>2</sup>C manual<sup>4</sup> must be met. Both SCL and SDA lines are open-drain I/Os with diodes to VDD and VSS. They should be connected to external pull-up resistors. To avoid signal contention, the microcontroller must only drive SDA and SCL low. The external pull-up resistors (e.g. R<sub>p</sub> = 10 kΩ) are required to pull the signal high. For dimensioning resistor sizes please take bus capacity and communication frequency into account (see for example Section 7.1 of NXP's I<sup>2</sup>C Manual for more details<sup>4</sup>). It should be noted that pull-up resistors may be included in I/O circuits of microcontrollers.

The die pad or center pad is electrically connected to GND. Hence, electrical considerations do not impose constraints on the wiring of the die pad. However, for mechanical stability it is recommended to solder the center pad to the PCB.

## 4 Absolute Minimum and Maximum Ratings

Stress levels beyond those listed in **Table 5** may cause permanent damage to the device. These are stress ratings only and functional operation of the device at these conditions cannot be guaranteed. Exposure to the absolute maximum rating conditions for extended periods may affect the reliability of the device.

Parameter	Rating
Supply voltage V <sub>DD</sub>	-0.3 V to +2.16 V
Supply voltage V <sub>DDH</sub>	-0.3 V to +2.16 V
Storage temperature range	-40 to +125°C
Operating temperature range	-40 to +85°C
Humidity Range	10% - 95% (non-condensing)
ESD HBM	2 kV
ESD CDM	500 V
Latch up, JEDEC Class II, 125°C	100 mA

**Table 5** Absolute minimum and maximum ratings.

Please contact Sensirion for storage, handling and assembly instructions.

## 5 Timing Specifications

### 5.1 Sensor System Timings

Default conditions of 25°C and 1.8V supply voltage apply to values in the table below, unless otherwise stated. The timings refer to the power up and reset of the ASIC part and do not reflect the usefulness of the readings.

Parameter	Symbol	Condition	Min.	Typ.	Max.	Unit	Comments
Power-up time	t <sub>PU</sub>	After hard reset, V <sub>DD</sub> ≥ V <sub>POR</sub>	-	0.4	0.6	ms	-
Soft reset time	t <sub>SR</sub>	After soft reset	-	0.4	0.6	ms	-

**Table 6** System timing specifications. Specifications are at 25°C and typical VDD.

### 5.2 Communication Timings

Default conditions of 25 °C and 1.8 V supply voltage apply to values in the table below, unless otherwise stated.

<sup>4</sup> [http://www.nxp.com/documents/user\\_manual/UM10204.pdf](http://www.nxp.com/documents/user_manual/UM10204.pdf)

Parameter	Symbol	Conditions	Min.	Typ.	Max.	Units	Comments
SCL clock frequency	$f_{SCL}$	-	0	-	400	kHz	-
Hold time (repeated) START condition	$t_{HD,STA}$	After this period, the first clock pulse is generated	0.6	-	-	$\mu s$	-
LOW period of the SCL clock	$t_{LOW}$	-	1.3	-	-	$\mu s$	-
HIGH period of the SCL clock	$t_{HIGH}$	-	0.6	-	-	$\mu s$	-
Set-up time for a repeated START condition	$t_{SU,STA}$	-	0.6	-	-	$\mu s$	-
SDA hold time	$t_{HD,DAT}$	-	0	-	-	ns	-
SDA set-up time	$t_{SU,DAT}$	-	100	-	-	ns	-
SCL/SDA rise time	$t_R$	-	-	-	300	ns	-
SCL/SDA fall time	$t_F$	-	-	-	300	ns	-
SDA valid time	$t_{VD,DAT}$	-	-	-	0.9	$\mu s$	-
Set-up time for STOP condition	$t_{SU,STO}$	-	0.6	-	-	$\mu s$	-
Capacitive load on bus line	$C_B$	-			400	pF	-

**Table 7** Communication timing specifications. Specifications are at 25°C and typical VDD.

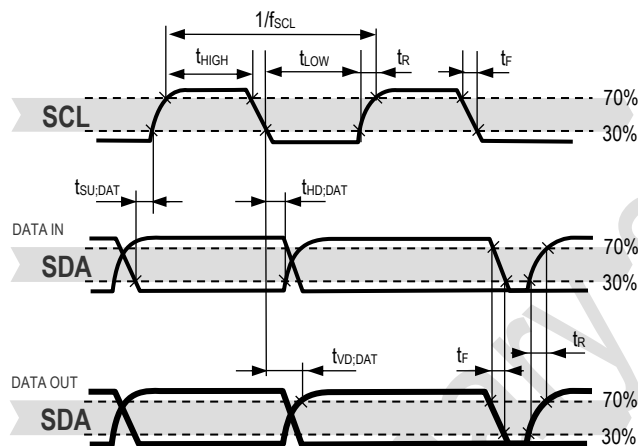

**Figure 8** Timing diagram for digital input/output pads. SDA directions are seen from the sensor. Bold SDA lines are controlled by the sensor; plain SDA lines are controlled by the micro-controller. Note that SDA valid read time is triggered by falling edge of preceding toggle.

## 6 Operation and Communication

The SGP30 supports I<sup>2</sup>C fast mode. For detailed information on the I<sup>2</sup>C protocol, refer to NXP I<sup>2</sup>C-bus specification<sup>4</sup>. All SGP30 commands and data are mapped to a 16-bit address space. Additionally, data and commands are protected with a CRC checksum to increase the communication reliability. The 16-bit commands that are sent to the sensor already include a 3-bit CRC checksum. Data sent from and received by the sensor is always succeeded by an 8-bit CRC.

In write direction it is mandatory to transmit the checksum, since the SGP30 only accepts data if it is followed by the correct checksum. In read direction it is up to the master to decide if it wants to read and process the checksum.

SGP30	Hex. Code
I <sup>2</sup> C address	0x58

**Table 8** I<sup>2</sup>C device address.

The typical communication sequence between the I<sup>2</sup>C master (e.g., a microcontroller in a host device) and the sensor is described as follows:

1. The sensor is powered up, communication is initialized
2. The I<sup>2</sup>C master periodically requests measurement and reads data, in the following sequence:
  - a. I<sup>2</sup>C master sends a measurement command
  - b. I<sup>2</sup>C master waits until the measurement is finished, either by waiting for the maximum execution time or by waiting for the expected duration and then poll data until the read header is acknowledged by the sensor (expected durations are listed in **Table 9**)
  - c. I<sup>2</sup>C master reads out the measurement result

## 6.1 Power-Up and Communication Start

The sensor starts powering-up after reaching the power-up threshold voltage  $V_{POR}$  specified in **Table 6**. After reaching this threshold voltage, the sensor needs the time  $t_{PU}$  to enter the idle state. Once the idle state is entered it is ready to receive commands from the master.

Each transmission sequence begins with a START condition (S) and ends with a STOP condition (P) as described in the I<sup>2</sup>C-bus specification.

## 6.2 Measurement Communication Sequence

A measurement communication sequence consists of a START condition, the I<sup>2</sup>C write header (7-bit I<sup>2</sup>C device address plus 0 as the write bit) and a 16-bit measurement command. The proper reception of each byte is indicated by the sensor. It pulls the SDA pin low (ACK bit) after the falling edge of the 8th SCL clock to indicate the reception. With the acknowledgement of the measurement command, the SGP30 starts measuring.

When the measurement is in progress, no communication with the sensor is possible and the sensor aborts the communication with a NACK condition.

After the sensor has completed the measurement, the master can read the measurement results by sending a START condition followed by an I<sup>2</sup>C read header. The sensor will acknowledge the reception of the read header and responds with data. The response data length is listed in **Table 9** and is structured in data words, where one word consists of two bytes of data followed by one byte CRC checksum. Each byte must be acknowledged by the microcontroller with an ACK condition for the sensor to continue sending data. If the sensor does not receive an ACK from the master after any byte of data, it will not continue sending data.

After receiving the checksum for the last word of data, a NACK and STOP condition have to be sent (see **Figure 9**).

The I<sup>2</sup>C master can abort the read transfer with a NACK followed by a STOP condition after any data byte if it is not interested in subsequent data, e.g. the CRC byte or following data bytes, in order to save time. Note that the data cannot be read more than once, and access to data beyond the specified amount will return a pattern of 1s.

## 6.3 Measurement Commands

The available measurement commands of the SGP30 are listed in **Table 9**.

### Feature Set

The SGP30 features a versioning system for the available set of measurement commands and on-chip algorithms. This so called feature set version number can be read out by sending a "Get\_feature\_set\_version" command. The sensor responds with 2 data bytes (MSB first) and 1 CRC byte. This feature set version number is used to refer to a corresponding set of available measurement commands as listed in **Table 9**.

### Air Quality Signals

The SGP30 uses a dynamic baseline correction algorithm and on-chip calibration parameters to provide two complementary air quality signals. Based on the sensor signals a total VOC signal (TVOC) and a CO<sub>2</sub> equivalent signal (CO<sub>2</sub>eq) are calculated. Sending an "Init\_air\_quality" command starts the air quality measurement. After the "Init\_air\_quality" command, a "Measure\_air\_quality" command has to be sent in regular intervals of 1s to ensure proper operation of the dynamic baseline correction algorithms. The sensor responds with 2 data bytes (MSB first) and 1 CRC byte for each of the two preprocessed air quality signals in the order CO<sub>2</sub>eq (ppm) and TVOC (ppb).

The SGP30 also provides the possibility to read and write the baseline values of the baseline correction algorithm. This feature is used to save the baseline in regular intervals on an external non-volatile memory and restore it after a new power-up or soft reset of the sensor. The command "Get\_baseline" returns the baseline values for the two air quality signals. The sensor



responds with 2 data bytes (MSB first) and 1 CRC byte for each of the two values in the order CO<sub>2</sub>eq and TVOC. These two values should be stored on an external memory. After a power-up or soft reset, the baseline of the baseline correction algorithm can be restored by using the “Set\_baseline” command with the two baseline values as parameters in the order as (TVOC, CO<sub>2</sub>eq). An example implementation of a generic driver for the baseline algorithm can be found in the document *SGP30\_driver\_integration\_guide*.

A new “Init\_air\_quality” command has to be sent after every power-up or soft reset.

### Sensor Signals

The command “Measure\_signals” is intended for part verification and testing purposes. It returns the sensor signals which are used as inputs for the on-chip calibration and baseline correction algorithms as shown in **Figure 6**. The command performs a measurement to which the sensor responds with 2 data bytes (MSB first) and 1 CRC byte (see **Figure 9**) for 2 sensor signals in the order H<sub>2</sub>\_signal (S<sub>out\_H2</sub>) and Ethanol\_signal (S<sub>out\_EthOH</sub>). Both signals can be used to calculate gas concentrations *c* relative to a reference concentration *c<sub>ref</sub>* by

$$\ln\left(\frac{c}{c_{ref}}\right) = \frac{S_{ref} - S_{out}}{a}$$

with *a* = 512 (9-bit shift), *S<sub>ref</sub>* the H<sub>2</sub>\_signal or Ethanol\_signal output at the reference concentration, and *S<sub>out</sub>* = *S<sub>out\_H2</sub>*

OR *S<sub>out</sub>* = *S<sub>out\_EthOH</sub>*.

### Measure Test

The command “Measure\_test” which is included for integration and production line testing runs an on-chip self-test. In case of a successful self-test the sensor returns the fixed data pattern 0xD400 (with correct CRC).

Feature Set	0x0009	Parameter length, including CRC [bytes]	Response length, including CRC [bytes]	Measurement duration [ms]	
				Typ.	Max.
Init_air_quality	0x2003	-	-	1	10
Measure_air_quality	0x2008	-	6	40	50
Get_Baseline	0x2015	-	6	10	10
Set_Baseline	0x201e	6	-	10	10
Measure_test	0x2032	-	3	200	220
Get_feature_set_version	0x202f	-	3	1	2
Measure_signals	0x2050	-	6	180	200

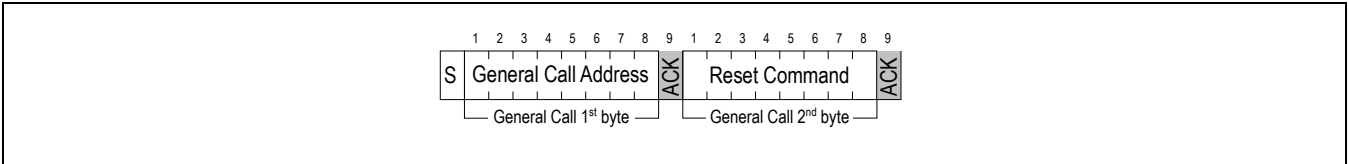

**Table 9** Measurement commands.

## 6.4 Soft Reset

A sensor reset can be generated using the “General Call” mode according to I<sup>2</sup>C-bus specification. It is important to understand that a reset generated in this way is not device specific. All devices on the same I<sup>2</sup>C bus that support the General Call mode will perform a reset. The appropriate command consists of two bytes and is shown in **Table 10**.

Command	Hex. Code
Address byte	0x00
Second byte	0x06
Reset Command using the General Call address	0x0006



**Table 10** Reset through the General Call address (Clear blocks are controlled by the microcontroller, grey blocks by the sensor.)

### 6.5 Get Serial ID

The readout of the serial ID register can be used to identify the chip and verify the presence of the sensor. The appropriate command structure is shown in **Table 11**. After issuing the measurement command and sending the ACK Bit the sensor needs the time  $t_{IDLE} = 0.5\text{ms}$  to respond to the I<sup>2</sup>C read header with an ACK Bit. Hence, it is recommended to wait  $t_{IDLE} = 0.5\text{ms}$  before issuing the read header.

The get serial ID command returns 3 words, and every word is followed by an 8-bit CRC checksum. Together the 3 words constitute a unique serial ID with a length of 48 bits.

The ID returned with this command are represented in the big endian (or MSB first) format.

Command	Hex. Code
Get Serial ID	0x3682

**Table 11** Get serial ID command.

### 6.6 Checksum Calculation

The 8-bit CRC checksum transmitted after each data word is generated by a CRC algorithm. Its properties are displayed in **Table 12**. The CRC covers the contents of the two previously transmitted data bytes. To calculate the checksum only these two previously transmitted data bytes are used.

Property	Value
Name	CRC-8
Width	8 bit
Protected Data	read and/or write data
Polynomial	0x31 ( $x^8 + x^5 + x^4 + 1$ )
Initialization	0xFF
Reflect input	False
Reflect output	False
Final XOR	0x00
Examples	CRC (0xBEEF) = 0x92

**Table 12** I<sup>2</sup>C CRC properties.

## 6.7 Communication Data Sequences

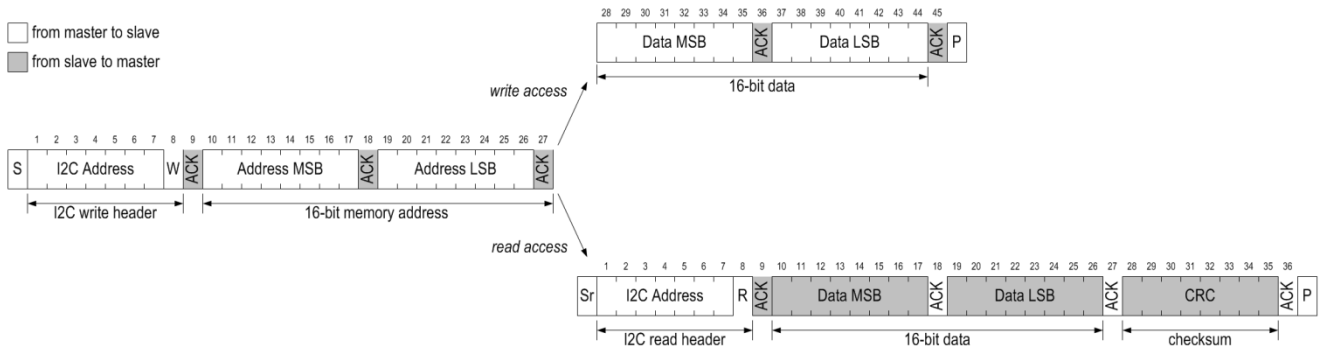

**Figure 9** Communication sequence for starting a measurement and reading measurement results.

## 7 Quality

### 7.1 Environmental Stability

The qualification of the SGP30 will be performed based on the JEDEC JESD47 qualification test method.

### 7.2 Material Contents

The device is fully RoHS and WEEE compliant, e.g., free of Pb, Cd, and Hg.

## 8 Device Package

SGP30 sensors are provided in a DFN (dual flat no leads) package with an outline of  $2.45 \times 2.45 \times 0.9 \text{ mm}^3$  and a terminal pitch of 0.8 mm. The circular sensor opening of maximally 1.6 mm diameter is centered on the top side of the package. The sensor chip is assembled on a Ni/Pd/Au plated copper lead frame. Sensor chip and lead frame are over-molded by a black, epoxy-based mold compound. Please note that the side walls of the package are diced and therefore the lead frame sidewall surfaces are not plated. SGP30

### 8.1 Traceability

All SGP30 sensors are laser marked for simple identification and traceability. The marking on the sensor consists of the product name and a 4-digit, alphanumeric tracking code. This code is used by Sensirion for batch-level tracking throughout production, calibration, and testing. Detailed tracking data can be provided upon justified request. The pin-1 location is indicated by the keyhole pattern in the light-colored central area. See **Figure 10** for illustration.



**Figure 10** Laser marking on SGP30. The pin-1 location is indicated by the keyhole pattern in the light-colored central area. The bottom line contains a 4-digit alphanumeric tracking code

## 8.2 Package Outline

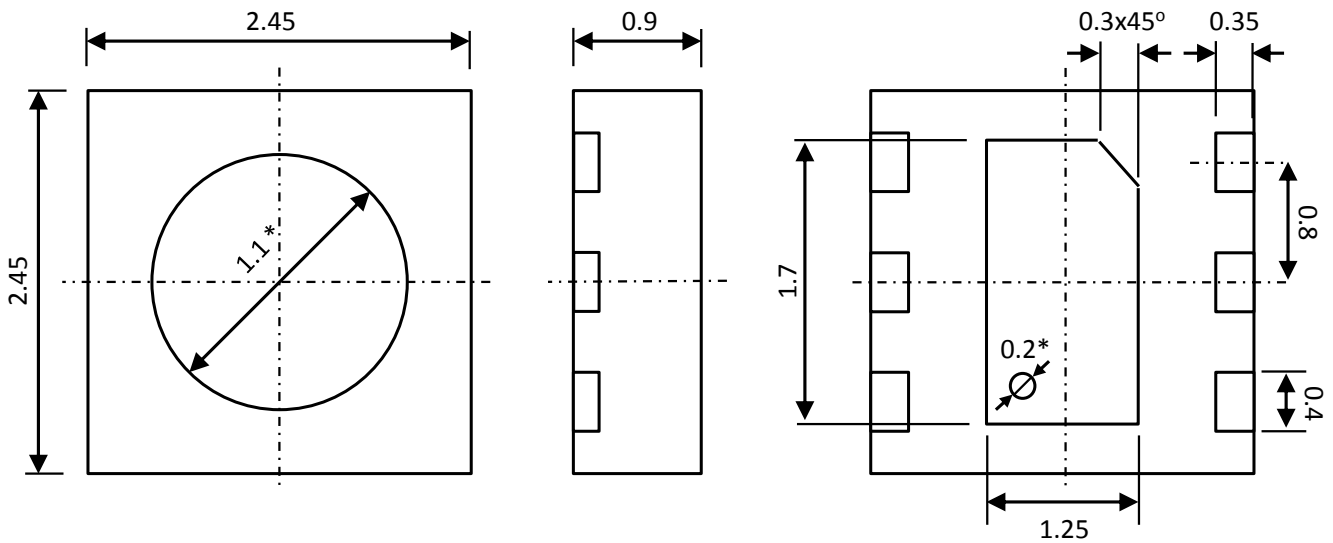

**Figure 11** Package outlines drawing of the SGP30 with nominal values. Dimensions are given in millimeters. The die pad shows a small recess in the bottom left part. \* These dimensions are not well defined and given as a reference only.

## 8.3 Landing Pattern

**Figure 12** shows the PCB landing pattern. The landing pattern is understood to be the metal layer on the PCB, onto which the DFN pads are soldered. The solder mask is understood to be the insulating layer on top of the PCB covering the copper traces. It is recommended to design the solder mask as a Non-Solder Mask Defined (NSMD) type. For solder paste printing it is recommended to use a laser-cut, stainless steel stencil with electro-polished trapezoidal walls and with 0.125 to 0.150 mm stencil thickness. The length of the stencil apertures for the I/O pads should be the same as the PCB pads. However, the position of the stencil apertures should have an offset of 0.1 mm away from the package center, as indicated in **Figure 12**. The die pad aperture should cover 70 – 90 % of the die pad area, resulting in a size of about 1.05 mm x 1.5 mm. For information on the soldering process and further recommendation on the assembly process please contact Sensirion.

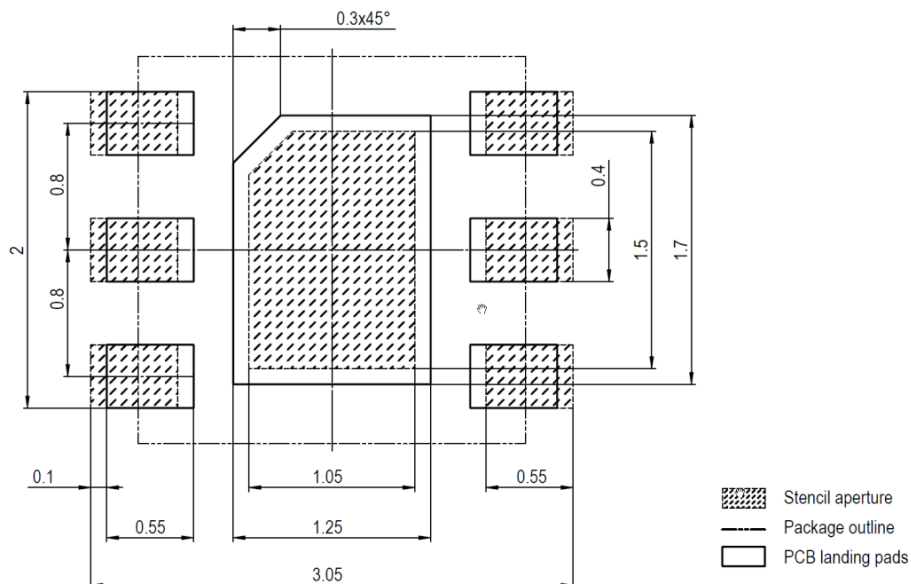
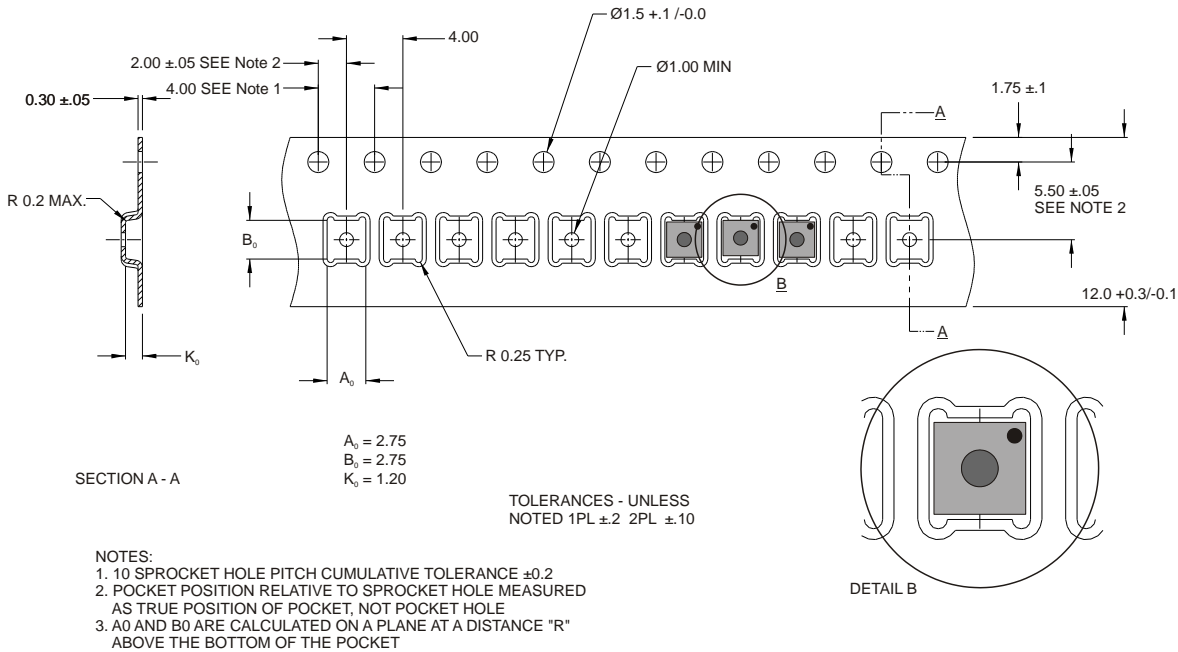

**Figure 12** Recommended landing pattern.

## 9 Ordering Information

Samples are available upon request. Please contact Sensirion.

## 10 Tape & Reel Package



**Figure 13** Technical drawing of the packaging tape with sensor orientation in tape. Header tape is to the right and trailer tape to the left on this drawing. Dimensions are given in millimeters.

## 11 Important Notices

### 11.1 Warning, Personal Injury

**Do not use this product as safety or emergency stop devices or in any other application where failure of the product could result in personal injury. Do not use this product for applications other than its intended and authorized use. Before installing, handling, using or servicing this product, please consult the data sheet and application notes. Failure to comply with these instructions could result in death or serious injury.**

If the Buyer shall purchase or use SENSIRION products for any unintended or unauthorized application, Buyer shall defend, indemnify and hold harmless SENSIRION and its officers, employees, subsidiaries, affiliates and distributors against all claims, costs, damages and expenses, and reasonable attorney fees arising out of, directly or indirectly, any claim of personal injury or death associated with such unintended or unauthorized use, even if SENSIRION shall be allegedly negligent with respect to the design or the manufacture of the product.

### 11.2 ESD Precautions

The inherent design of this component causes it to be sensitive to electrostatic discharge (ESD). To prevent ESD-induced damage and/or degradation, take customary and statutory ESD precautions when handling this product.

See application note "ESD, Latchup and EMC" for more information.

### 11.3 Warranty

SENSIRION warrants solely to the original purchaser of this product for a period of 12 months (one year) from the date of delivery that this product shall be of the quality, material and workmanship defined in SENSIRION's published specifications of the product. Within such period, if proven to be defective, SENSIRION shall repair and/or replace this product, in SENSIRION's discretion, free of charge to the Buyer, provided that:

- notice in writing describing the defects shall be given to SENSIRION within fourteen (14) days after their appearance;
- such defects shall be found, to SENSIRION's reasonable satisfaction, to have arisen from SENSIRION's faulty design, material, or workmanship;
- the defective product shall be returned to SENSIRION's factory at the Buyer's expense; and
- the warranty period for any repaired or replaced product shall be limited to the unexpired portion of the original period.

This warranty does not apply to any equipment which has not been installed and used within the specifications recommended by SENSIRION for the intended and proper use of the equipment. EXCEPT FOR THE WARRANTIES EXPRESSLY SET FORTH HEREIN, SENSIRION MAKES NO WARRANTIES, EITHER EXPRESS OR IMPLIED, WITH RESPECT TO THE PRODUCT. ANY AND ALL WARRANTIES, INCLUDING WITHOUT LIMITATION, WARRANTIES OF MERCHANTABILITY OR FITNESS FOR A PARTICULAR PURPOSE, ARE EXPRESSLY EXCLUDED AND DECLINED. SENSIRION is only liable for defects of this product arising under the conditions of operation provided for in the data sheet and proper use of the goods. SENSIRION explicitly disclaims all warranties, express or implied, for any period during which the goods are operated or stored not in accordance with the technical specifications.

SENSIRION does not assume any liability arising out of any application or use of any product or circuit and specifically disclaims any and all liability, including without limitation consequential or incidental damages. All operating parameters, including without limitation recommended parameters, must be validated for each customer's applications by customer's technical experts. Recommended parameters can and do vary in different applications. SENSIRION reserves the right, without further notice, (i) to change the product specifications and/or the information in this document and (ii) to improve reliability, functions and design of this product.

Copyright © 2017 by SENSIRION.

CMOSens® is a trademark of Sensirion.

All rights reserved.

## 12 Headquarters and Subsidiaries

### **Sensirion AG**

Laubisruetistr. 50  
CH-8712 Staefa ZH  
Switzerland

phone: +41 44 306 40 00  
fax: +41 44 306 40 30  
[info@sensirion.com](mailto:info@sensirion.com)  
[www.sensirion.com](http://www.sensirion.com)

### **Sensirion Taiwan Co. Ltd**

phone: +886 3 5506701  
[info@sensirion.com](mailto:info@sensirion.com)  
[www.sensirion.com](http://www.sensirion.com)

### **Sensirion Inc., USA**

phone: +1 312 690 5858  
[info-us@sensirion.com](mailto:info-us@sensirion.com)  
[www.sensirion.com](http://www.sensirion.com)

### **Sensirion Japan Co. Ltd.**

phone: +81 3 3444 4940  
[info-jp@sensirion.com](mailto:info-jp@sensirion.com)  
[www.sensirion.co.jp](http://www.sensirion.co.jp)

### **Sensirion Korea Co. Ltd.**

phone: +82 31 337 7700~3  
[info-kr@sensirion.com](mailto:info-kr@sensirion.com)  
[www.sensirion.co.kr](http://www.sensirion.co.kr)

### **Sensirion China Co. Ltd.**

phone: +86 755 8252 1501  
[info-cn@sensirion.com](mailto:info-cn@sensirion.com)  
[www.sensirion.com.cn](http://www.sensirion.com.cn)

To find your local representative, please visit [www.sensirion.com/distributors](http://www.sensirion.com/distributors)