

DATA SHEET

SURFACE-MOUNT CERAMIC MULTILAYER CAPACITORS

High-Voltage

NP0/X7R

1 KV TO 3 KV

10 pF to 33 nF

RoHS compliant & Halogen Free



SCOPE

This specification describes High-Voltage NP0/X7R series chip capacitors with lead-free terminations.

APPLICATIONS

PCs, Hard disk, Game PCs
Power supplies
LCD panel
ADSL, Modem

FEATURES

Supplied in tape on reel
Nickel-barrier end termination
RoHS compliant
Halogen Free compliant

ORDERING INFORMATION-GLOBAL PART NUMBER, PHYCOMP

CTC & I2NC

All part numbers are identified by the series, size, tolerance, TC material, packing style, voltage, process code, termination and capacitance value.

YAGEO BRAND ordering code

GLOBAL PART NUMBER (PREFERRED)

CC XXXX X X XXX X **B** X XXX
(1) (2) (3) (4) (5) (6) (7)

(1) SIZE – INCH BASED (METRIC)

0805 (2012) / 1206 (3216) / 1210 (3225) / 1808 (4520) / 1812 (4532)

(2) TOLERANCE

C = ±0.25 pF
D = ±0.5 pF
G = ±2%
J = ±5%
K = ±10%
M = ±20%

(3) PACKING STYLE

R = Paper/PE taping reel; Reel 7 inch
K = Blister taping reel; Reel 7 inch
P = Paper/PE taping reel; Reel 13 inch
F = Blister taping reel; Reel 13 inch
C = Bulk case

(4) TC MATERIAL

NPO
X7R

(5) RATED VOLTAGE

C = 1 KV
D = 2 KV
S = 2.5KV
E = 3 KV

(6) PROCESS

N = NPO
B = Class 2 MLCC

(7) CAPACITANCE VALUE

2 significant digits+number of zeros
The 3rd digit signifies the multiplying factor, and letter R is decimal point
Example: 121 = 12 × 10¹ = 120 pF

CONSTRUCTION

The capacitor consists of a rectangular block of ceramic dielectric in which a number of interleaved metal electrodes are contained. This structure gives rise to a high capacitance per unit volume.

The inner electrodes are connected to the two end terminations and finally covered with a layer of plated tin (NiSn). The terminations are lead-free. A cross section of the structure is shown in Fig.1.

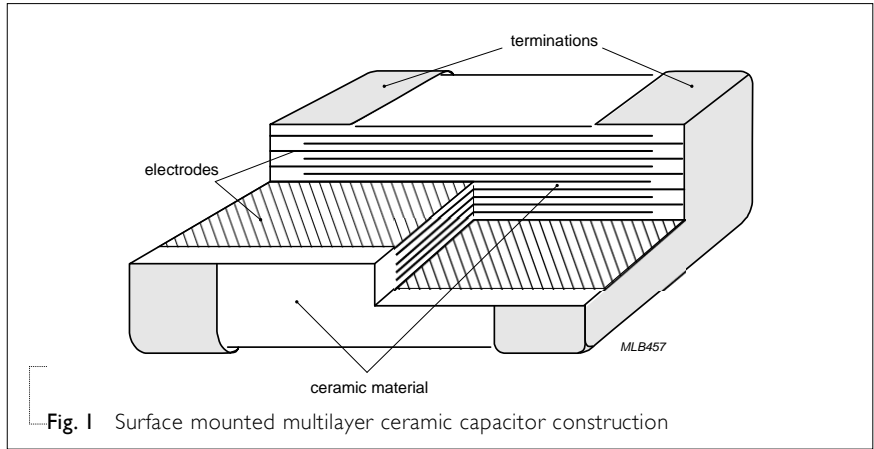

Fig. 1 Surface mounted multilayer ceramic capacitor construction

DIMENSION

Table I For outlines see fig. 2

TYPE	L ₁ (mm)	W (mm)	T (MM)	L ₂ / L ₃ (mm)		L ₄ (mm)
				min.	max.	min.
0805	2.0 ±0.20	1.25 ±0.20	Refer to table 2 to 4	0.25	0.75	0.70
1206	3.2 ±0.30	1.6 ±0.20		0.25	0.75	1.40
1210	3.2 ±0.30	2.5 ±0.20		0.25	0.75	1.40
1808	4.5 ±0.40	2.0 ±0.30		0.25	0.75	2.20
1812	4.5 ±0.40	3.2 ±0.20		0.25	0.75	2.20

OUTLINES

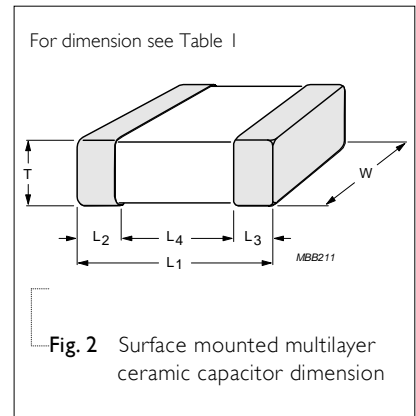

Fig. 2 Surface mounted multilayer ceramic capacitor dimension

CAPACITANCE RANGE & THICKNESS FOR NP0

Table 2 Sizes from 0805 to 1812

CAP.	0805			1206			1210			1808			1812		
	1 KV	1 KV	2 KV	3 KV	1 KV	2 KV	1 KV	2 KV	3 KV	1 KV	2 KV	3 KV	1 KV	2 KV	3 KV
10 pF	0.85±0.1	1.25±0.2	1.25±0.2	1.25±0.2								1.6±0.2	1.25±0.2	1.25±0.2	1.25±0.2
12 pF	0.85±0.1	1.25±0.2	1.25±0.2	1.25±0.2								1.6±0.2	1.25±0.2	1.25±0.2	1.25±0.2
15 pF	0.85±0.1	1.25±0.2	1.25±0.2	1.25±0.2								1.6±0.2	1.25±0.2	1.25±0.2	1.25±0.2
18 pF	0.85±0.1	1.25±0.2	1.25±0.2	1.25±0.2								1.6±0.2	1.25±0.2	1.25±0.2	1.25±0.2
22 pF	0.85±0.1	1.25±0.2	1.25±0.2	1.25±0.2								1.6±0.2	1.25±0.2	1.25±0.2	1.25±0.2
27 pF	0.85±0.1	1.25±0.2	1.25±0.2	1.25±0.2								1.6±0.2	1.25±0.2	1.25±0.2	1.25±0.2
33 pF	0.85±0.1	1.25±0.2	1.25±0.2	1.25±0.2	1.25±0.2	1.25±0.2	1.25±0.2	1.25±0.2	1.6±0.2	1.25±0.2	1.25±0.2	1.25±0.2	1.25±0.2	1.25±0.2	1.25±0.2
39 pF	0.85±0.1	1.25±0.2	1.25±0.2	1.25±0.2	1.25±0.2	1.25±0.2	1.25±0.2	1.25±0.2	1.6±0.2	1.25±0.2	1.25±0.2	1.25±0.2	1.25±0.2	1.25±0.2	1.25±0.2
47 pF	0.85±0.1	1.25±0.2	1.25±0.2	1.25±0.2	1.25±0.2	1.25±0.2	1.25±0.2	1.25±0.2	1.6±0.2	1.25±0.2	1.25±0.2	1.25±0.2	1.25±0.2	1.25±0.2	1.25±0.2
56 pF		1.25±0.2	1.25±0.2		1.25±0.2	1.25±0.2	1.25±0.2	1.25±0.2	1.6±0.2	1.25±0.2	1.25±0.2	1.25±0.2	1.25±0.2	1.25±0.2	1.25±0.2
68 pF		1.25±0.2	1.25±0.2		1.25±0.2	1.25±0.2	1.25±0.2	1.25±0.2	1.6±0.2	1.25±0.2	1.25±0.2	1.25±0.2	1.25±0.2	1.25±0.2	1.25±0.2
82 pF		1.25±0.2	1.25±0.2		1.25±0.2	1.25±0.2	1.25±0.2	1.25±0.2	1.6±0.2	1.25±0.2	1.25±0.2	1.25±0.2	1.25±0.2	1.25±0.2	1.25±0.2
100 pF		1.25±0.2	1.25±0.2		1.25±0.2	1.25±0.2	1.25±0.2	1.25±0.2	1.6±0.2	1.25±0.2	1.25±0.2	1.25±0.2	1.25±0.2	1.25±0.2	1.25±0.2
120 pF		1.25±0.2	1.25±0.2		1.25±0.2	1.25±0.2	1.25±0.2	1.25±0.2		1.25±0.2	1.25±0.2	1.25±0.2	1.25±0.2	1.25±0.2	1.25±0.2
150 pF		1.25±0.2	1.25±0.2		1.25±0.2	1.25±0.2	1.25±0.2	1.25±0.2		1.25±0.2	1.25±0.2	1.25±0.2	1.25±0.2	1.25±0.2	1.25±0.2
180 pF		1.25±0.2	1.25±0.2		1.25±0.2	1.25±0.2	1.25±0.2	1.25±0.2		1.25±0.2	1.25±0.2	1.25±0.2	1.25±0.2	1.25±0.2	1.25±0.2
220 pF		1.25±0.2	1.25±0.2		1.25±0.2	1.25±0.2	1.25±0.2	1.25±0.2		1.25±0.2	1.25±0.2	1.25±0.2	1.25±0.2	1.25±0.2	1.25±0.2
270 pF		1.25±0.2			1.25±0.2		1.25±0.2	1.25±0.2		1.25±0.2	1.25±0.2		1.25±0.2	1.25±0.2	
330 pF		1.25±0.2			1.25±0.2		1.25±0.2	1.25±0.2		1.25±0.2	1.25±0.2		1.25±0.2	1.25±0.2	
390 pF		1.25±0.2			1.25±0.2		1.25±0.2	1.25±0.2		1.25±0.2	1.25±0.2		1.25±0.2	1.25±0.2	
470 pF		1.25±0.2			1.25±0.2		1.25±0.2	1.25±0.2		1.25±0.2	1.25±0.2		1.25±0.2	1.25±0.2	
560 pF		1.25±0.2			1.25±0.2		1.25±0.2	1.25±0.2		1.25±0.2	1.25±0.2		1.25±0.2	1.25±0.2	
680 pF		1.25±0.2			1.25±0.2		1.25±0.2			1.25±0.2	1.25±0.2		1.25±0.2	1.25±0.2	
820 pF		1.25±0.2			1.25±0.2					1.25±0.2	1.25±0.2		1.25±0.2	1.25±0.2	
1.0 nF		1.25±0.2			1.25±0.2					1.25±0.2	1.25±0.2		1.25±0.2	1.25±0.2	
1.2 nF										1.25±0.2			1.25±0.2		
1.5 nF										1.25±0.2					
1.8 nF															
2.2 nF															
2.7 nF															
3.3 nF															

NOTE

1. Values in shaded cells indicate thickness class in mm
2. Capacitance value of non E-12 series is on request

CAPACITANCE RANGE & THICKNESS FOR X7R

Table 3 Sizes from 0805 to 1812

CAP.	0805		1206		1210		1808			1812		
	1 KV	1 KV	2 KV	2.5KV	1 KV	2 KV	1 KV	2 KV	3 KV	1 KV	2 KV	3 KV
100 pF												
150 pF	0.85±0.1								1.6±0.2			
220 pF	0.85±0.1	1.25±0.2	1.25±0.2		1.25±0.2	1.25±0.2			1.6±0.2			
330 pF	0.85±0.1	1.25±0.2	1.25±0.2		1.25±0.2	1.25±0.2		1.35±0.15	1.6±0.2			
470 pF	0.85±0.1	1.25±0.2	1.25±0.2		1.25±0.2	1.25±0.2	1.35±0.15	1.35±0.15	1.6±0.2			
680 pF	0.85±0.1	1.25±0.2	1.25±0.2		1.25±0.2	1.25±0.2	1.35±0.15	1.35±0.15	1.6±0.2			
1.0 nF	0.85±0.1	1.25±0.2	1.25±0.2	1.6±0.2	1.25±0.2	1.25±0.2	1.35±0.15	1.35±0.15	2.0±0.2	1.35±0.15	1.35±0.15	1.6±0.2
1.5 nF	1.25±0.2	1.25±0.2	1.25±0.2		1.25±0.2	1.25±0.2	1.35±0.15	1.35±0.15	2.0±0.2	1.35±0.15	1.35±0.15	
2.2 nF	1.25±0.2	1.25±0.2			1.25±0.2	1.60±0.2	1.35±0.15	1.6±0.2		1.35±0.15	1.35±0.15	
3.3 nF	1.25±0.2	1.25±0.2			1.25±0.2		1.35±0.15			1.35±0.15	1.35±0.15	
4.7 nF		1.25±0.2			1.25±0.2		1.35±0.15			1.35±0.15	1.35±0.15	
6.8 nF		1.25±0.2			1.25±0.2		1.6±0.2			1.35±0.15		
10 nF		1.25±0.2			1.25±0.2		1.6±0.2			1.35±0.15		
15 nF					1.25±0.2					1.35±0.15		
22 nF						1.6±0.2				1.35±0.15		
33 nF										1.6±0.2		
47 nF												
68 nF												
100 nF												

NOTE

1. Values in shaded cells indicate thickness class in mm
2. Capacitance value of non E-6 series is on request
3. For products with 5% tolerance, please contact local sales force before ordering

THICKNESS CLASSES AND PACKING QUANTITY

Table 5

SIZE CODE	THICKNESS CLASSIFICATION	TAPE WIDTH QUANTITY PER REEL	Ø180 MM / 7 INCH		Ø330 MM / 13 INCH		QUANTITY PER BULK CASE
			Paper	Blister	Paper	Blister	
0201	0.3 ±0.03 mm	8 mm	15,000	---	50,000	---	---
0402	0.5 ±0.05 mm	8 mm	10,000	---	50,000	---	50,000
0603	0.8 ±0.1 mm	8 mm	4,000	---	15,000	---	15,000
0805	0.6 ±0.1 mm	8 mm	4,000	---	20,000	---	10,000
	0.8 / 0.85 ±0.1 mm	8 mm	4,000	---	15,000	---	8,000
	1.00 ±0.1 mm	8 mm	---	3,000	---	10,000	---
	1.25 ±0.2 mm	8 mm	---	3,000	---	10,000	5,000
1206	0.6 ±0.1 mm	8 mm	4,000	---	20,000	---	---
	0.8 / 0.85 ±0.1 mm	8 mm	4,000	---	15,000	---	---
	1.00 / 1.15 ±0.1 mm	8 mm	---	3,000	---	10,000	---
	1.25 ±0.2 mm	8 mm	---	3,000	---	10,000	---
	1.6 ±0.15 mm	8 mm	---	2,500	---	10,000	---
	1.6 ±0.2 mm	8 mm	---	2,000	---	8,000	---
1210	0.6 / 0.7 ±0.1 mm	8 mm	---	4,000	---	15,000	---
	0.85 ±0.1 mm	8 mm	---	4,000	---	10,000	---
	1.15 ±0.1 mm	8 mm	---	3,000	---	10,000	---
	1.15 ±0.15 mm	8 mm	---	3,000	---	10,000	---
	1.25 ±0.2 mm	8 mm	---	3,000	---	---	---
	1.5 ±0.1 mm	8 mm	---	2,000	---	---	---
	1.6 / 1.9 ±0.2 mm	8 mm	---	2,000	---	---	---
	2.0 ±0.2 mm	8 mm	---	2,000 1,000	---	---	---
1808	1.15 ±0.15 mm	12 mm	---	3,000	---	---	---
	1.25 ±0.2 mm	12 mm	---	3,000	---	---	---
	1.35 ±0.15 mm	12 mm	---	2,000	---	---	---
	1.5 ±0.1 mm	12 mm	---	2,000	---	---	---
	1.6 ±0.2 mm	12 mm	---	2,000	---	---	---
	2.0 ±0.2 mm	12 mm	---	2,000	---	---	---
1812	0.6 / 0.85 ±0.1 mm	12 mm	---	2,000	---	---	---
	1.15 ±0.1 mm	12 mm	---	1,000	---	---	---
	1.15 ±0.15 mm	12 mm	---	1,000	---	---	---
	1.25 ±0.2 mm	12 mm	---	1,000	---	---	---
	1.35 ±0.15 mm	12 mm	---	1,000	---	---	---
	1.5 ±0.1 mm	12 mm	---	1,000	---	---	---
	1.6 ±0.2 mm	12 mm	---	1,000	---	---	---
	2.0 ±0.2 mm	12 mm	---	1,000	---	---	---
2.5 ±0.2 mm	12 mm	---	500	---	---	---	

ELECTRICAL CHARACTERISTICS

NP0/X7R DIELECTRIC CAPACITORS; NISN TERMINATIONS

Unless otherwise stated all electrical values apply at an ambient temperature of 20±1 °C, an atmospheric pressure of 86 to 106 kPa, and a relative humidity of 63 to 67%.

Table 6

DESCRIPTION		VALUE
Capacitance range		10 pF to 33 nF
Capacitance tolerance		
NP0	C < 10 pF	±0.25 pF, ±0.5 pF
	C ≥ 10 pF	±2%, ±5%
X7R		±5% ⁽¹⁾ , ±10%
Dissipation factor (D.F.)		
NP0	C < 30 pF	≤ 1 / (400 + 20C)
	C ≥ 30 pF	≤ 0.1 %
X7R		≤ 2.5 %
Insulation resistance after 1 minute at U _r (DC)		R _{ins} ≥ 10 GΩ or R _{ins} × C ≥ 500 seconds whichever is less
Maximum capacitance change as a function of temperature (temperature characteristic/coefficient):		
NP0		±30 ppm/°C
X7R		±15%
Operating temperature range:		
NP0/X7R		-55 °C to +125 °C

NOTE

1. ±5% tolerance of capacitance value isn't available for X7R full product range, please contact local sales force before ordering

HIGH-VOLTAGE NP0

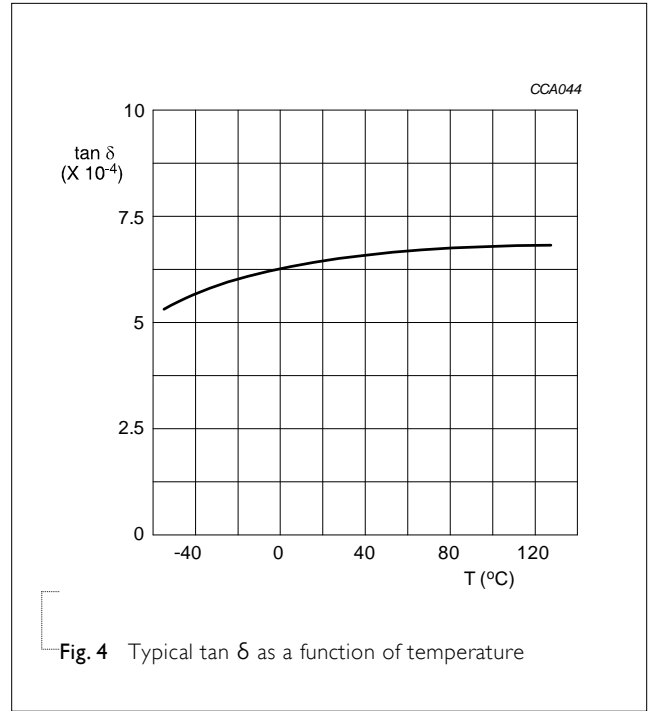
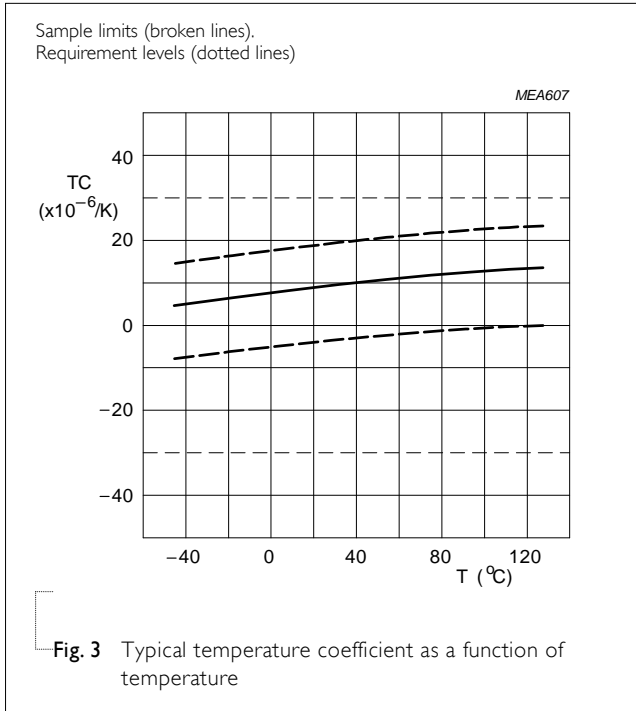

HIGH-VOLTAGE X7R

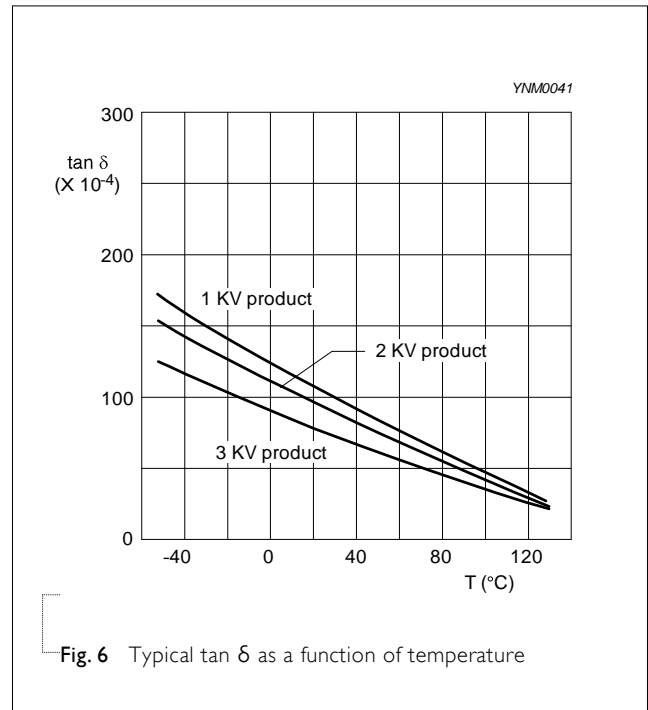
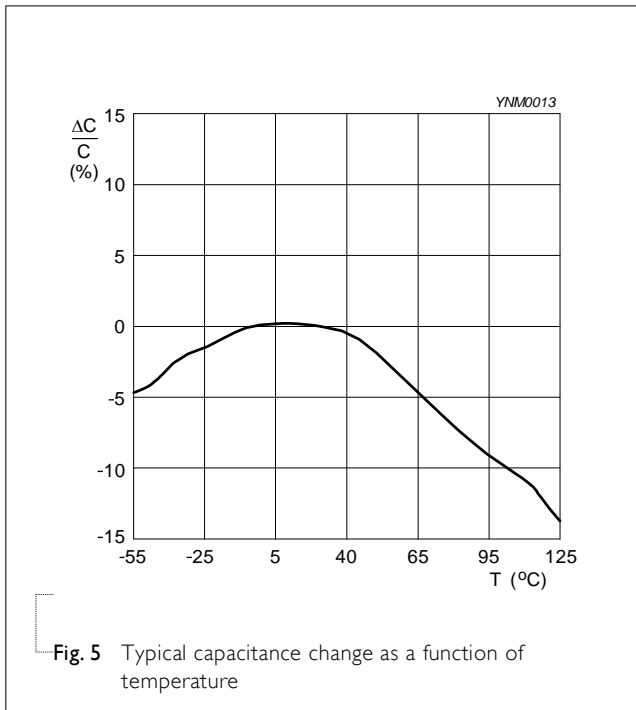

SOLDERING RECOMMENDATION

Table 7

SOLDERING METHOD	SIZE				
	0402	0603	0805	1206	≥ 1210
Reflow	Reflow only	≥ 1.0 μF	≥ 2.2 μF	≥ 4.7 μF	Reflow only
Reflow/Wave	---	< 1.0 μF	< 2.2 μF	< 4.7 μF	---

TESTS AND REQUIREMENTS

Table 8 Test procedures and requirements

TEST	TEST METHOD	PROCEDURE	REQUIREMENTS
Mounting	IEC 60384-21/22 4.3	The capacitors may be mounted on printed-circuit boards or ceramic substrates	No visible damage
Visual Inspection and Dimension Check	4.4	Any applicable method using × 10 magnification	In accordance with specification
Capacitance	4.5.1	Class 1: f = 1 MHz for C ≤ 1 nF, measuring at voltage 1 V _{rms} at 20 °C f = 1 KHz for C > 1 nF, measuring at voltage 1 V _{rms} at 20 °C Class 2: f = 1 KHz for C ≤ 10 μF, measuring at voltage 1 V _{rms} at 20 °C	Within specified tolerance
Dissipation Factor (D.F.)	4.5.2	Class 1: f = 1 MHz for C ≤ 1 nF, measuring at voltage 1 V _{rms} at 20 °C f = 1 KHz for C > 1 nF, measuring at voltage 1 V _{rms} at 20 °C Class 2: f = 1 KHz for C ≤ 10 μF, measuring at voltage 1 V _{rms} at 20 °C	In accordance with specification
Insulation Resistance	4.5.3	U _r ≤ 500 V: At U _r for 1 minute U _r > 500 V: At 500 V for 1 minute	In accordance with specification

TEST	TEST METHOD	PROCEDURE	REQUIREMENTS									
Temperature Coefficient	4.6	Capacitance shall be measured by the steps shown in the following table. The capacitance change should be measured after 5 min at each specified temperature stage.	<General purpose series> Class I: $\Delta C/C: \pm 30\text{ppm}$ Class 2: X7R: $\Delta C/C: \pm 15\%$ Y5V: $\Delta C/C: 22\sim -82\%$ <High Capacitance series> Class 2: X7R/X5R: $\Delta C/C: \pm 15\%$ Y5V: $\Delta C/C: 22\sim -82\%$									
		<table border="1"> <thead> <tr> <th>Step</th> <th>Temperature(°C)</th> </tr> </thead> <tbody> <tr> <td>a</td> <td>25±2</td> </tr> <tr> <td>b</td> <td>Lower temperature±3°C</td> </tr> <tr> <td>c</td> <td>25±2</td> </tr> <tr> <td>d</td> <td>Upper Temperature±2°C</td> </tr> <tr> <td>e</td> <td>25±2</td> </tr> </tbody> </table> <p>(1) Class I Temperature Coefficient shall be calculated from the formula as below $\text{Temp. Coefficient} = \frac{C2 - C1}{C1 \times \Delta T} \times 10^6 \text{ [ppm/°C]}$ C1: Capacitance at step c C2: Capacitance at 125°C $\Delta T: 100^\circ\text{C}(=125^\circ\text{C}-25^\circ\text{C})$</p> <p>(2) Class II Capacitance Change shall be calculated from the formula as below $\Delta C = \frac{C2 - C1}{C1} \times 100\%$ C1: Capacitance at step c C2: Capacitance at step b or d</p>		Step	Temperature(°C)	a	25±2	b	Lower temperature±3°C	c	25±2	d
Step	Temperature(°C)											
a	25±2											
b	Lower temperature±3°C											
c	25±2											
d	Upper Temperature±2°C											
e	25±2											
Adhesion	IEC 60384-21/22	4.7 A force applied for 10 seconds to the line joining the terminations and in a plane parallel to the substrate	Force size $\geq 0603: 5\text{N}$									
Bending Strength		4.8 Mounting in accordance with IEC 60384-22 paragraph 4.3 Conditions: bending 1 mm at a rate of 1 mm/s, radius jig 5 mm	No visible damage $\Delta C/C$ Class 1: NP0: within $\pm 1\%$ or 0.5 pF, whichever is greater Class 2: X7R: $\pm 10\%$									

TEST	TEST METHOD	PROCEDURE	REQUIREMENTS
Resistance to Soldering Heat	4.9	<p>Precondition: 150 +0/-10 °C for 1 hour, then keep for 24 ±1 hours at room temperature</p> <p>Preheating: for size ≤ 1206: 120 °C to 150 °C for 1 minute</p> <p>Preheating: for size >1206: 100 °C to 120 °C for 1 minute and 170 °C to 200 °C for 1 minute</p> <p>Solder bath temperature: 260 ±5 °C</p> <p>Dipping time: 10 ±0.5 seconds</p> <p>Recovery time: 24 ±2 hours</p>	<p>Dissolution of the end face plating shall not exceed 25% of the length of the edge concerned</p> <hr/> <p>$\Delta C/C$ Class 1: NP0: within ±0.5% or 0.5 pF, whichever is greater Class2: X7R: ±10%</p> <hr/> <p>D.F. within initial specified value R_{ins} within initial specified value</p>
Solderability	4.10	<p>Preheated to a temperature of 80 °C to 140 °C and maintained for 30 seconds to 60 seconds.</p> <p>1. Temperature: 235±5°C / Dipping time: 2 ±0.5 s 2. Temperature: 245±5°C / Dipping time: 3 ±0.5 s (lead free)Depth of immersion: 10mm</p>	<p>The solder should cover over 95% of the critical area of each termination</p>
Rapid Change of Temperature	IEC 60384-21/22 4.11	<p>Preconditioning: 150 +0/-10 °C for 1 hour, then keep for 24 ±1 hours at room temperature</p> <p>5 cycles with following detail: 30 minutes at lower category temperature 30 minutes at upper category temperature</p> <p>Recovery time 24 ±2 hours</p>	<p>No visual damage</p> <hr/> <p>$\Delta C/C$ Class 1: NP0: within ±1% or 1 pF, whichever is greater Class2: X7R: ±15%</p> <hr/> <p>D.F. meet initial specified value R_{ins} meet initial specified value</p>
Damp Heat	4.13	<p>1. Preconditioning, class 2 only: 150 +0/-10 °C /1 hour, then keep for 24 ±1 hour at room temp</p> <p>2. Initial measure: Spec: refer to initial spec C, D, IR</p> <p>3. Damp heat test: 500 ±12 hours at 40 ±2 °C; 90 to 95% R.H.</p> <p>4. Recovery: Class 1: 6 to 24 hours Class 2: 24 ±2 hours</p> <p>5. Final measure: C, D, IR</p> <p>P.S. If the capacitance value is less than the minimum value permitted, then after the other measurements have been made the capacitor shall be preconditioned according to "IEC 60384 4.1" and then the requirement shall be met.</p>	<p>No visual damage after recovery</p> <hr/> <p>$\Delta C/C$ Class 1: NP0: within ±2% or 1 pF, whichever is greater Class2: X7R: ±15%</p> <p>D.F. Class 1: NP0: ≤ 2 × specified value Class2: X7R: ≥ 25 V: ≤ 5%</p> <p>R_{ins} Class 1: NP0: ≥ 2,500 MΩ or $R_{ins} \times C_r \geq 25s$ whichever is less Class2: X7R: ≥ 500 MΩ or $R_{ins} \times C_r \geq 25s$ whichever is less</p>

TEST	TEST METHOD	PROCEDURE	REQUIREMENTS												
Endurance	IEC 60384-21/22 4.14	1. Preconditioning, class 2 only: 150 +0/-10 °C /1 hour, then keep for 24 ±1 hour at room temp 2. Initial measure: Spec: refer to initial spec C, D, IR Endurance test: Temperature: NP0/X7R: 125 °C Specified stress voltage applied for 1,000 hours. High-Voltage series follows the stress conditions below:	No visual damage <hr/> $\Delta C/C$ Class 1: NP0: within ±2% or 1 pF, whichever is greater Class 2: X7R: ±15% D.F. Class 1: NP0: ≤ 2 × specified value Class 2: X7R: ≥ 25 V: ≤ 5% R_{ins} Class 1: NP0: ≥ 4,000 MΩ or $R_{ins} \times C_r \geq 40s$ whichever is less Class 2: X7R: ≥ 1,000 MΩ or $R_{ins} \times C_r \geq 50s$ whichever is less												
		<table border="1" style="width: 100%; border-collapse: collapse;"> <thead> <tr> <th>Voltage</th> <th>NP0</th> <th>X7R</th> </tr> </thead> <tbody> <tr> <td>≤ 100V</td> <td>2.0 × Ur</td> <td>2.0 × Ur</td> </tr> <tr> <td>200/250V</td> <td>1.5 × Ur</td> <td>1.5 × Ur</td> </tr> <tr> <td>500/630V</td> <td>1.3 × Ur</td> <td>1.2 × Ur</td> </tr> <tr> <td>≥ 1KV</td> <td>1.2 × Ur</td> <td>1.1 × Ur</td> </tr> </tbody> </table> 3. Recovery time: 24 ±2 hours 4. Final measure: C, D, IR P.S. If the capacitance value is less than the minimum value permitted, then after the other measurements have been made the capacitor shall be preconditioned according to "IEC 60384 4.1" and then the requirement shall be met.		Voltage	NP0	X7R	≤ 100V	2.0 × Ur	2.0 × Ur	200/250V	1.5 × Ur	1.5 × Ur	500/630V	1.3 × Ur	1.2 × Ur
Voltage	NP0	X7R													
≤ 100V	2.0 × Ur	2.0 × Ur													
200/250V	1.5 × Ur	1.5 × Ur													
500/630V	1.3 × Ur	1.2 × Ur													
≥ 1KV	1.2 × Ur	1.1 × Ur													
Voltage Proof		Specified stress voltage applied for 1~5 seconds $U_r \leq 100 V$: series applied 2.5 U_r $100 V < U_r \leq 200 V$ series applied (1.5 $U_r + 100$) $200 V < U_r \leq 500 V$ series applied (1.3 $U_r + 100$) $U_r > 500 V$: 1.3 U_r $U_r \geq 1KV$: 1.2 U_r Charge/Discharge current less than 50mA	No breakdown or flashover												

REVISION HISTORY

REVISION	DATE	CHANGE NOTIFICATION	DESCRIPTION
Version 12	Dec. 01, 2020	-	- Add X7R/0805/1.5nF to 3.3nF/1KV
Version 11	Jul. 13, 2018	-	- Add NPO/1206/10pF to 47pF/3KV
Version 10	Mar. 7, 2017	-	- 0805 L4 spec updated
Version 9	Jan. 16, 2017	-	- Product range updated
Version 8	Oct. 12, 2015	-	- Product range updated
Version 7	May 21, 2014	-	- Product range updated
Version 6	Jun. 17, 2012	-	- Product range updated
Version 5	Sep 25, 2012	-	- Product range updated
Version 4	Aug 08, 2011	-	- Product range updated
Version 3	Jan 19, 2011	-	- Dimension updated - Add NP0 0805 1KV
Version 2	Feb 02, 2010	-	- Change to dual brand datasheet that describe High-Voltage NP0/X7R series with RoHS compliant - Replace the high voltage part of pdf files: UP-NP0X7R_HV_1K-to-4KV_I and UY-NP0X7R_HV_1K-to-4KV_I - Description of "Halogen Free compliant" added - Product range updated - Define global part number - Test method and procedure updated