

AI³®

RUTRONIK SYSTEM SOLUTIONS

FROM SINGLE PRODUCT TO SOLUTION, FROM BASIC LEVEL TO RESEARCH LEVEL

V. 2.0



Basic
Level



Design
Level



Adv. Design
Level









Research
Level

Introduction03
Basic Level04
Design Level06
 Thingy:5308
 TMF882X10
Advanced Design Level.....12
 RDK214
 RDK316
 RDK417
 RAB – Text to Speech18
 RAB1 – Sensorfusion20
 RAB2 – CO221
 RAB3 – Radar22
 RAB4 – RTK23
 HMS Anybus24
 HV-Switch25

Research Level26
 HESS28
 Electronic Nose30
 Odor Eliminator30
 Virus Killer31
 Insect Scare31
Smart Stations32
RSS Smartphone APP33
ModusToolbox™34
GitHub34

Innovation and future DNA

Our Product Portfolio





 Semiconductors	 Boards & Systems
 Passive Components	 Storage Technologies
 Electromechanical Components	 Wireless Technologies
 Displays & Monitors	

Our Initiatives





Follow us

-  www.facebook.com/rutronik
-  <https://twitter.com/rutronik>
-  www.youtube.com/user/rutronik24
-  <https://rutronik-tec.com>
-  www.linkedin.com/company/rutronik



Stephan Menze
Head of Global Innovation Management

How do we work?

- We combine the technical excellence of our departments to ignite Rutroniks full potential
- We give support to increase the number of sockets per application
- We communicate with suppliers or external partners like universities, engineering labs or patent holders to create cooperations on a technical or commercial level
- We find new innovative ways to address and support our customers and partners in the best possible way

What are the main benefits?

- We receive the customer and market feedback for new solutions, markets or applications which we could investigate in
- Our sales team addresses as many sockets as possible at a customer from technical and commercial perspective
- Together we increase Rutroniks influence and standing in the market
- Together we find the best ways to address and support our customers and deepen our customer relations
- Together we address the complete solution from our linecard to our customers to support them in the best way and create the best proof of concept to reduce their time to market

Committed to excellence

Consult – Know-how. Built-in.

The Technical Competence from RUTRONIK
Worldwide and individual consulting on the spot by competent sales staff, application engineers & product specialists.

Components – Variety. Built-in.

The Product Portfolio from RUTRONIK
Wide product range of semiconductors, passive and electromechanical components, displays & monitors, boards & systems, storage and wireless technologies for optimum coverage of your needs.

Logistics – Reliability. Built-in.

The Delivery Service from RUTRONIK
Innovative and flexible solutions: from supply chain management to individual logistics systems.

Quality – Security. Built-in.

Quality without Compromise from RUTRONIK
The integrated management system (IMS) encompasses quality control, information security, environmental protection, occupational health and safety.

From Basic Level to Research Level Significant improvement of excellence – across all levels

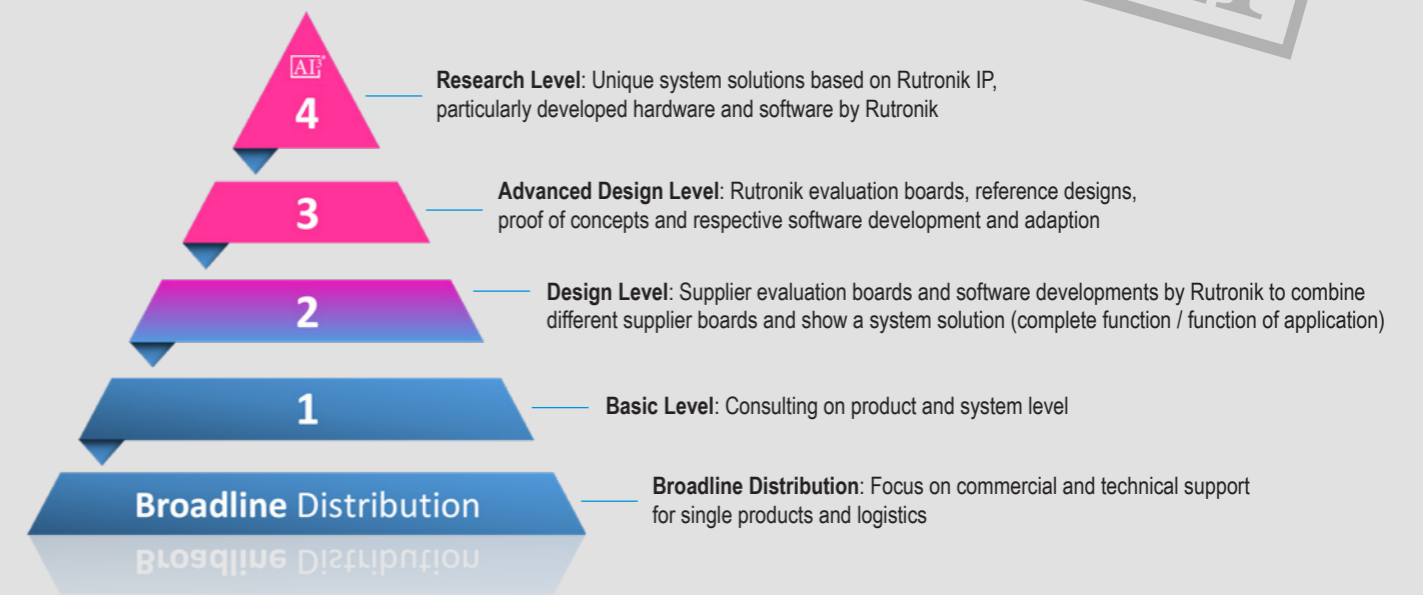



- Technical consulting on product and system level using diagrams, data sheets and training materials
- Technical consulting through product and application engineers
- Commercial consulting through sales regarding technologies, procurement and logistics

Customer advantage

- Inspiration system thinking, new technologies, new products
- Education training for new products
- Exchange with experts on application level



Innovation Level



Faster Time to Market



Consulting

Inspiration. Education. Exchange.



Our daily business is to support our customers by global supply and support for the full range of electronic components.

We rely on our core competencies and services - distribution in high scale and complexity.

Over the years, we accumulated many unique features that have only one purpose: to increase the competitiveness of our customers.

Due to our global presence and expert teams of sales staff, applications engineers and product specialists, we guarantee a high dynamic, highly professional assistance and support in all technical and commercial matters.

The unmatched breadth of our components range ensures that our customers' needs are optimally covered.

High availability combined with maximum safety and reliability based on our strong partnerships with leading manufacturers, external development partners or universities ensures that we maintain a technological edge.

The consistent focus on growth includes investments in our own research and development capacities.

We are aiming at developing new technologies on the one hand and on the other hand at designing highly innovative solutions – precisely tailored to our customers' needs and the expectations of their end users.







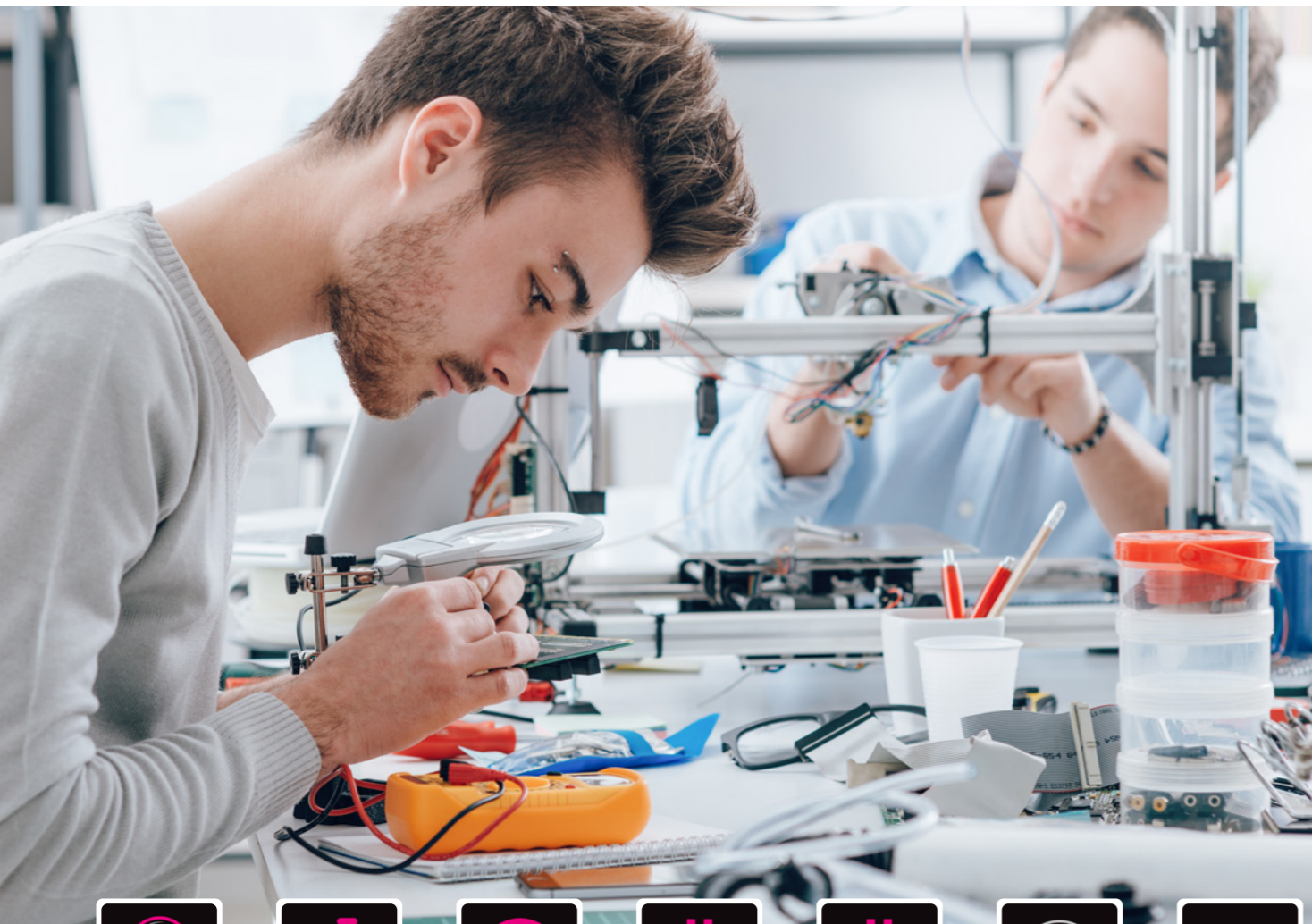

- Hardware platforms, evaluation kits and reference designs from suppliers as basis, optional combination of different boards
- Software adaption by Rutronik support engineers which connect different boards with each other to demonstrate the corresponding functions
- Support for implementing the respective software
- Consulting for the functions of the hardware/boards, functions of the products within the boards and system thinking combine different boards and eventually forming a system solution (overall function, application).

Customer advantage

- The Design Level System Solutions provide the quickest entry in standardised board level from suppliers and the corresponding software



						
Innovation Level	Faster Time to Market	Consulting	Standard HW (Supplier)	Standard HW (Rutronik)	Standard HW Adaption	SW Adaption (Rutronik)

Board - Overview

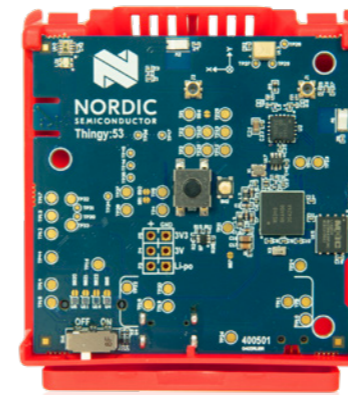

Nordic - Thingy:53

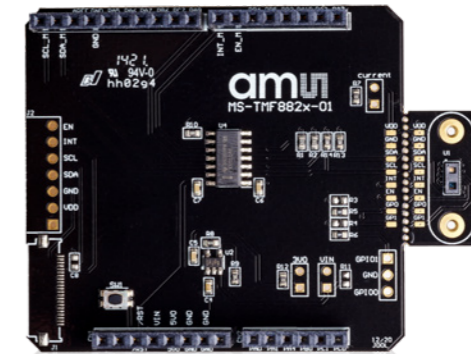

ams OSRAM - TMF882X





Nordic Thingy:53

Multi-protocol easy-to-use IoT prototyping platform

Benefits

- Makes it possible to create prototypes and proof-of-concepts without building custom hardware
- Thingy:53 is built around the nRF5340 dual-core wireless SoC
- Processing power and memory size of its dual Arm Cortex-M33 processors enables it to run embedded machine learning models directly on the device
- The nRF Edge Impulse app enables users to connect their Thingy:53 to their Edge Impulse studio account through a mobile device
- Allows wireless transfer of sensor data over Bluetooth LE to the mobile device and upload it to the cloud for training and download trained ML models to the Thingy:53 for deployment and inferencing
- App acts as the GUI for viewing inferencing results from a running ML model

Key Features

- Supports Bluetooth LE, Bluetooth mesh, Thread, Zigbee, Matter, proprietary 2.4 GHz, and NFC
- Enabled for embedded machine learning (ML)
- Environmental sensor for temperature, humidity, air quality and air pressure
- Color and light sensor
- Low-power accelerometer and inertial measurement unit (IMU)
- High-quality MEMS microphone and buzzer
- User-programmable buttons and RGB LED
- Rechargeable Li-Po battery with 1350mAh capacity

Markets & Applications

- Machine learning
- Smart home sensing
- Fast prototyping
- Proof-of-concept development

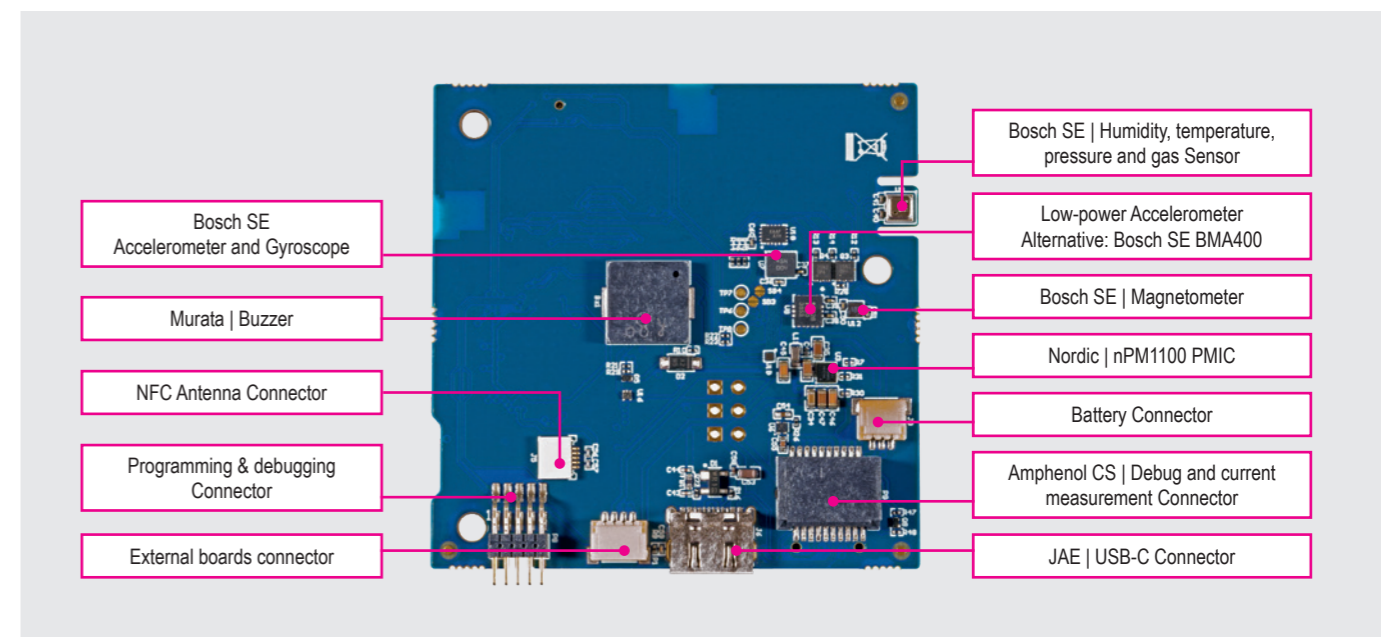
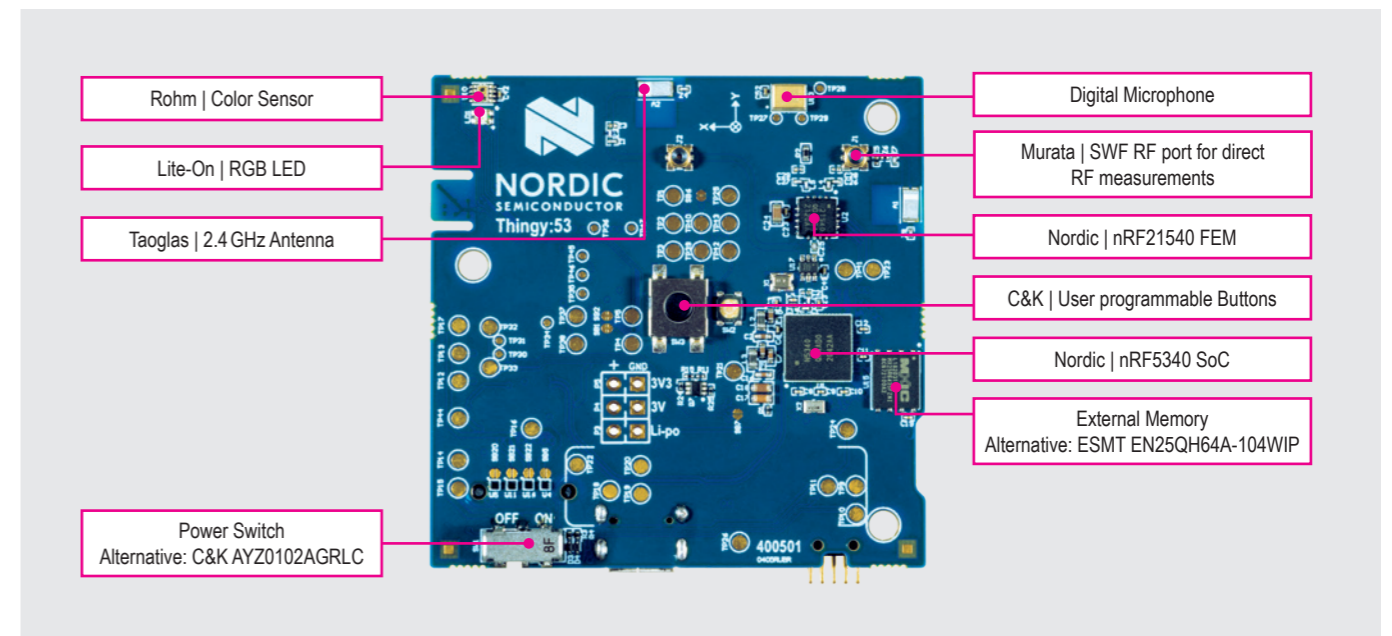
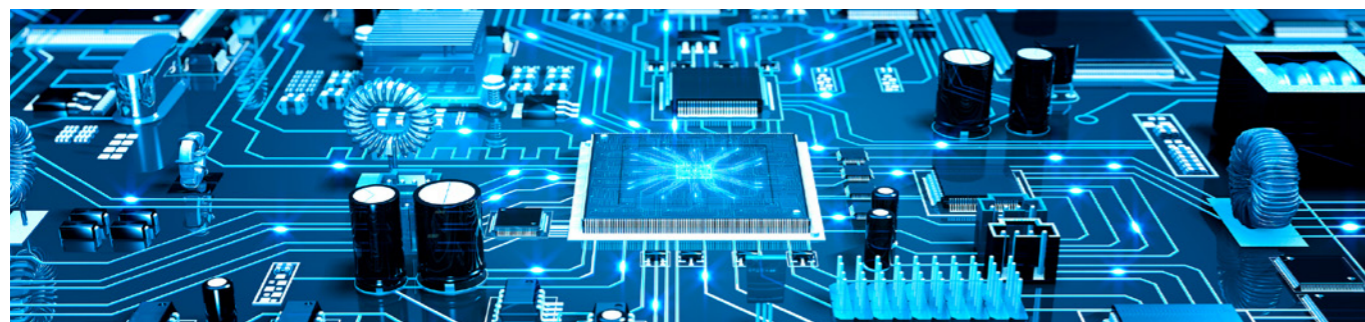



Arduino shield adapter board for TMF882x Time of flight sensor by ams OSRAM – Designed to fit on our RDK baseboards

Benefits

- Arduino form factor development board fits to all RDK baseboards
- Firmware examples available for an easy plug and play start
- You can use all RDKs as a base board for all other Rutronik adapter boards
- Easy integration of all other Rutronik adapter boards (e.g. Sensorfusion, CO2, T-t-S, etc.) or other Arduino based evaluation boards via integrated Arduino headers
- First class hard- and firmware support from our product experts and development engineers

Key Features

- TMF8828 sensor mounted on breakaway board
- Cover glass samples included, 0.5mm / 0.6mm / 0.7mm/ 0.8mm thicknesses
- Air gap spacer samples included, 0.17mm / 0.25mm / 0.38mm / 0.5mm thicknesses
- Breakaway board Vdd current sense test point
- Reset button
- Onboard LDO and I²C level shifter

Markets & Applications

- 3D Vision System
- 3D dToF for mobile AR
- Face Recognition
- Active Stereo Vision
- 2-Step Enrollment & Verification

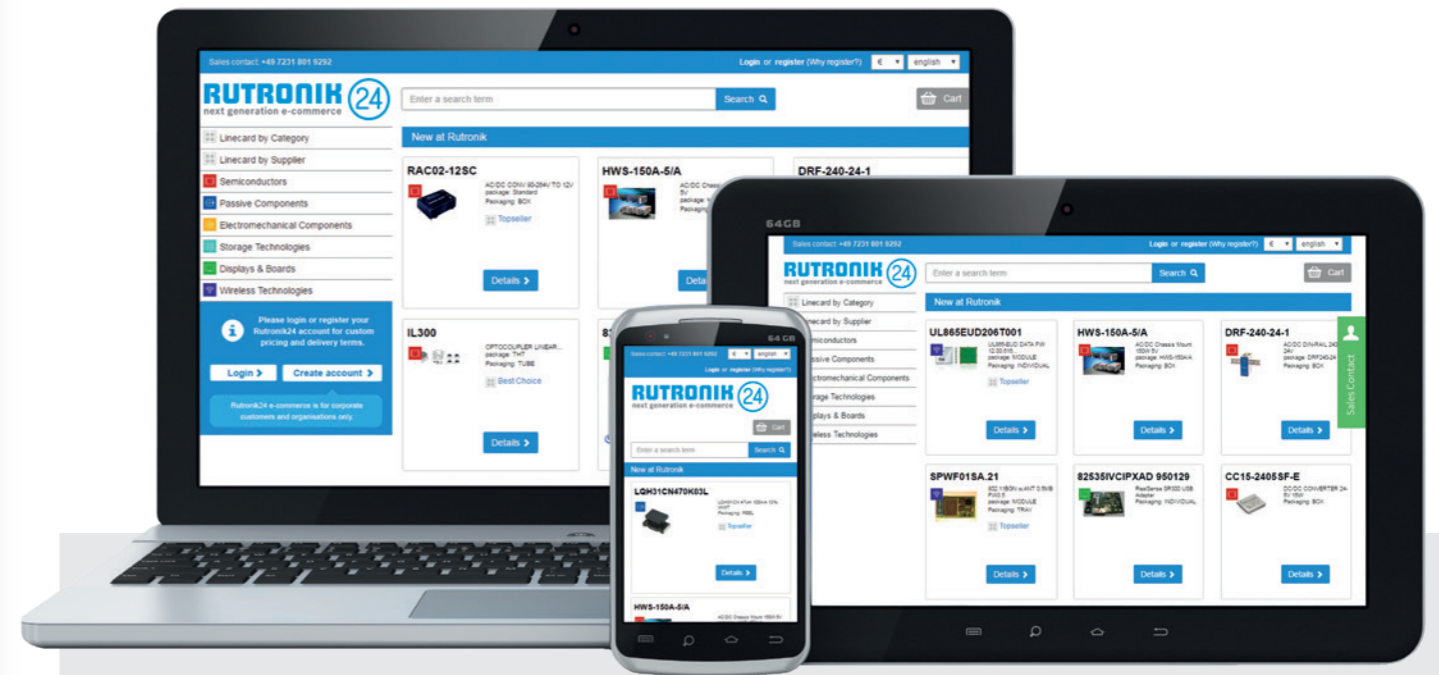
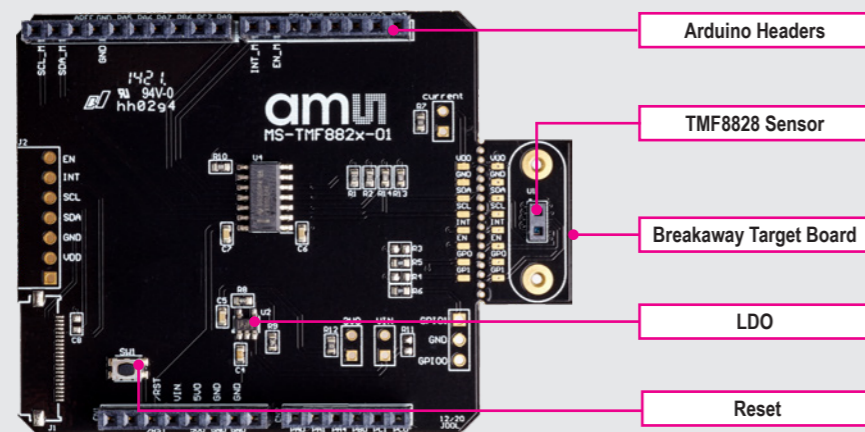

e-commerce made easy

FASTER. EASIER.
JUST MORE PERSONAL.

rutronik24.com

Advanced Design Level



- Own Rutronik hardware (platform/boards) and corresponding software development
- Usage of application modules based on these platforms
- Development of software adaptations for different application modules with self developed software
- Close cooperation with multiple suppliers through the modular set up of the Advanced Design Level System Solutions
- All key components are based on the portfolio of our suppliers
- Fusion of the know-how of multiple suppliers and Rutronik

Customer advantage

- Modular solution with the best fit combination of different suppliers and products
- Time to Market is reduced significantly
- Inspiration for best fit products







Innovation Level

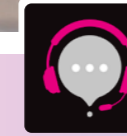

Faster Time to Market



Consulting



Standard HW (Rutronik)



App-specific HW Adaption



SW Adaption (Rutronik)



Close Cooperation

All components of the BOM can be found in the Rutronik portfolio!

Board - Overview

Rutronik Development Kits - RDK

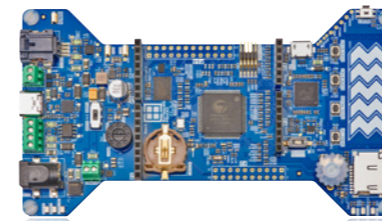

RDK2

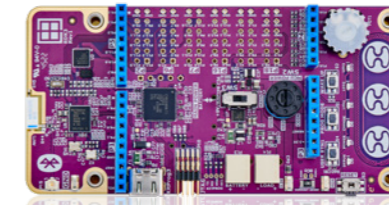

RDK3

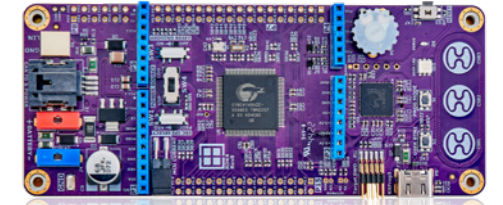

RDK4

Rutronik Adapter Boards - RAB



RAB - TTS

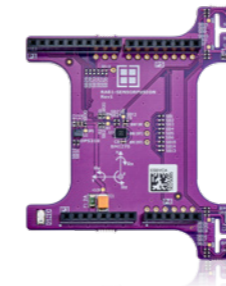

RAB1 - Sensorfusion



RAB2 - CO2

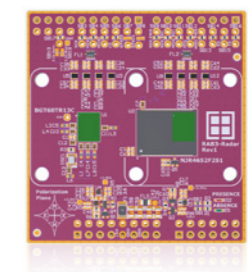

RAB3 - Radar



RAB4 - RTK

Rutronik Cooperation Boards



HMS Anybus



HV-Switch

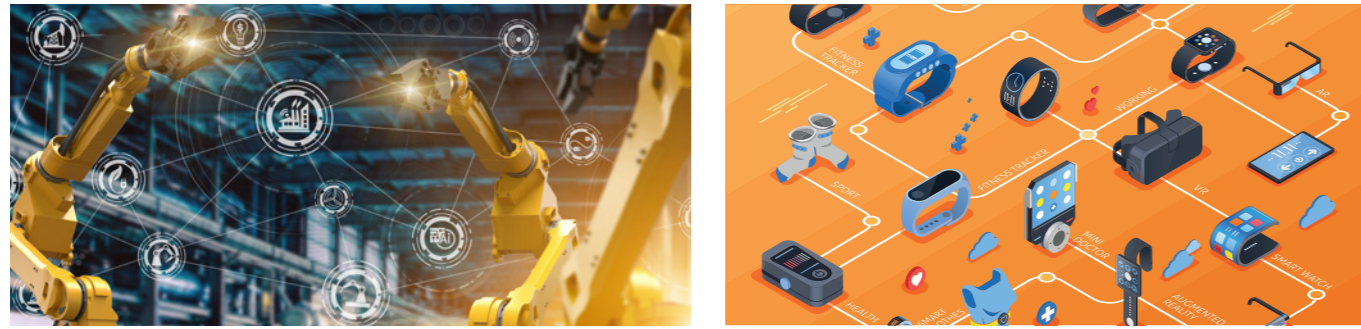

RDK2 based on Infineon PSoC™ 62 MCU

Easy approach for firm- and hardware designers

Benefits

- Offers a complete solution for hard- and firmware development and for proof of concepts in a very short time
- No need of soldering and assembling own prototype builds for first testing and measurements
- Use all RDKs as a base board for all other Rutronik adapter boards
- Easy integration of all other Rutronik adapter boards (e.g. Sensorfusion, CO2, Text-to-Speech, etc.) or other Arduino based evaluation boards via integrated Arduino headers
- Easy evaluation of all the available parts through provided state-of-the-art interfaces directly on the board
- First class hard- and firmware support from our product experts and development engineers

Key Features

- Boards runs on the PSoC™ 62 MCU with a dual core ARM® Cortex®-M4 and ARM® Cortex®-M0+ architecture
- Includes an integrated power management IC which enables the board to be powered from the Li-ION battery. The high-efficiency buck controller allows having a high-power supply providing developers with up to 3.5A at 5V
- A 512MBit SEMPER™ NOR Flash connected with microcontroller QSPI can be used to store large amounts of data or even the firmware that may run directly from it
- User can access all pins of the PSoC™ 62 MCU via supplied headers

Markets & Applications

- Smart Wearables
- IoT & Industrial IoT
- Smart Home
- Robotics & Automation
- Touch & Gesture based applications

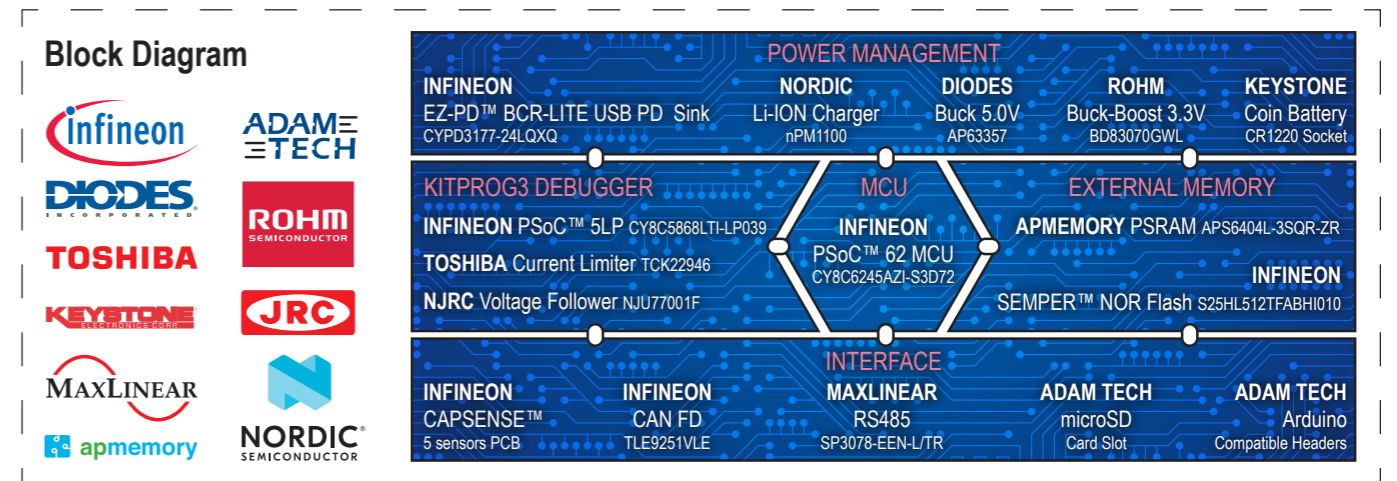
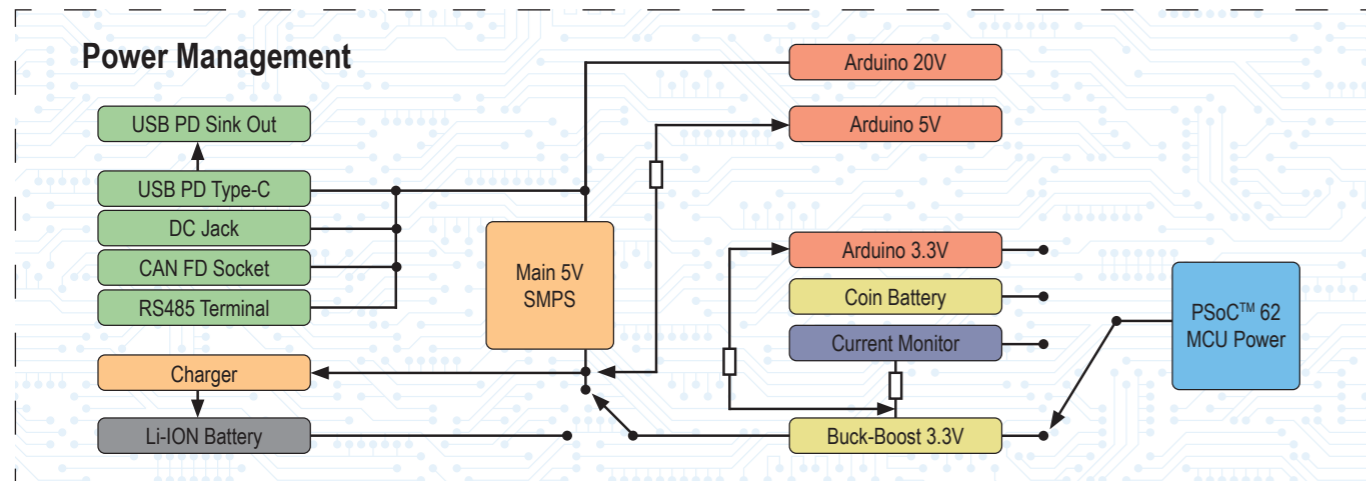
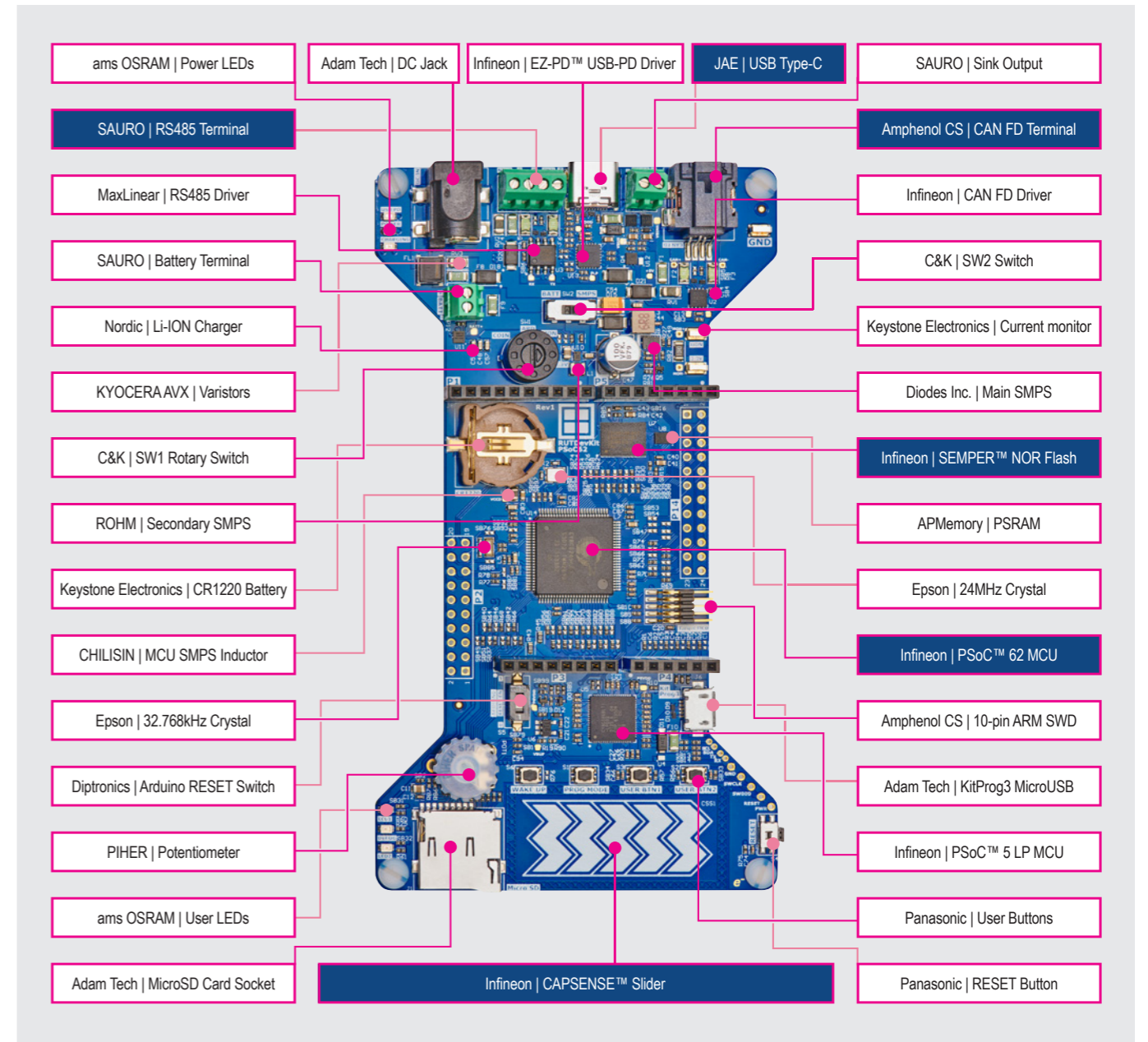
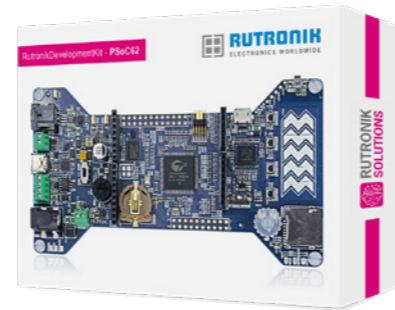



RDK3 based on Infineon PSoC™ 64 Secured MCU

Wireless ultra-low power IoT Bluetooth board with state of the art hardware-based security features

Benefits & Key Features

- Offers a complete solution for hardware and firmware developers for proof of concepts in a very short time
- Board runs on the PSoC™ 64 Secured MCU from Infineon with PSA support
- The MCU offers three-levels of hardware- and firmware-based resource isolation
- The Arm® Cortex®-M4/M0+ dual core SOC offers a secured M0+ core, physically separated from an user application running on the other M4 core
- Offers secure element functionality that can be used to build authenticate secure applications
- Ultra low power MCU with Bluetooth® Low Energy

Markets & Applications

- Smart Building
- Robotics
- Smart Factory
- Healthcare

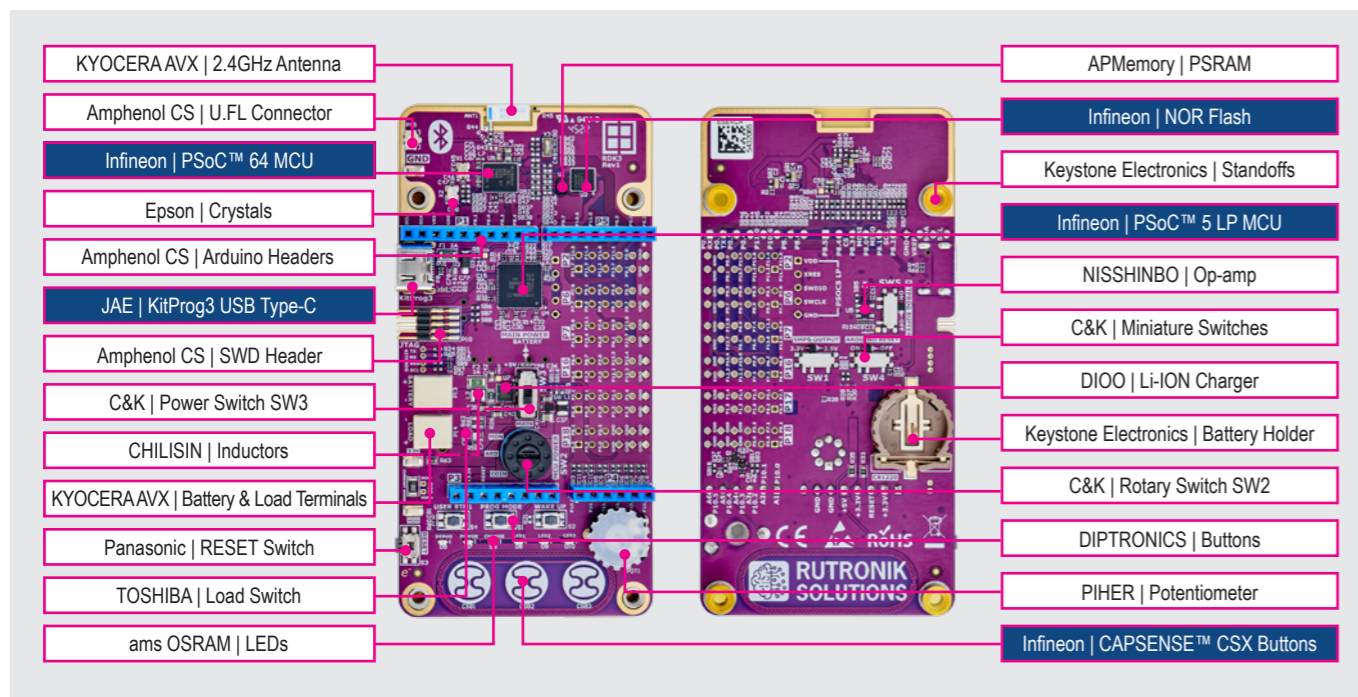

RDK4 based on Infineon PSoC™ 4100S Max

Small, compact automotive qualified controller with most important automotive interfaces like CAN-FD and LIN

Benefits & Key Features

- Board runs on the PSoC™ 4100S Max with Arm Cortex M0+ MCU (48MHz)
 - CAN-FD (5Mbps) | LIN Interface | Audio I2S | 384/32 KB Flash/SRAM
 - Low-Power 1.71 V to 5.5 V | CAPSENSE™
- Possibility for an easy current measurement with Jumpers
- All Pins reachable for digital analyses like CAN TX RX
- SBC – OPTIREG™ Mid-Range+ with WTD / Voltage Monitoring for Functional Safety
- Perfect fit for development of e.g. various modules like trunk control, door control, seat heating, climate control and many more...

Markets & Applications

- Automotive motor control modules
- Body & Convenience
- Powertrain
- Industrial HVAC
- Agriculture
- Factory Automation
- Human Machine Interface

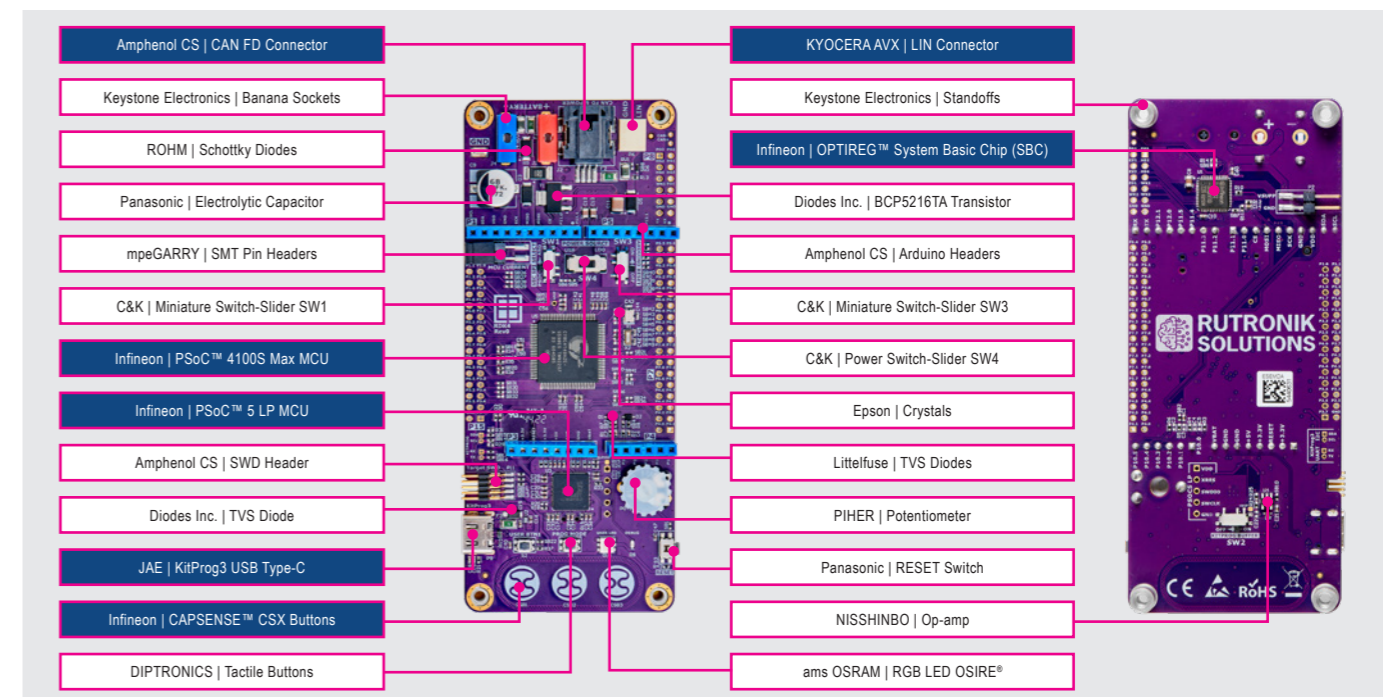

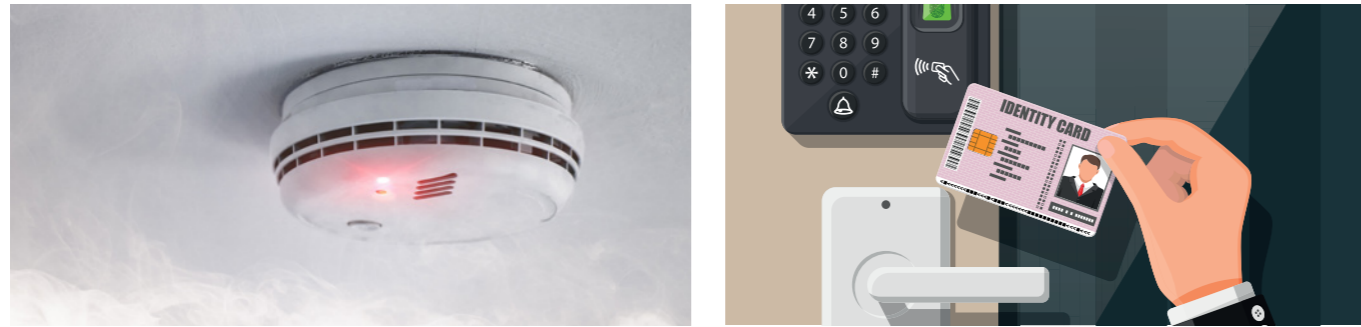

Adapter Board based on Epson Voice/Audio LSI S1V3G340

Easy approach for implementing voice guidance for a variety of HMI and IoT applications

Benefits

- Offers a complete solution for development of a voice guidance feature and for proof of concepts in a very short time
- No need of soldering and assembling own prototype builds for first testing and measurements
- You can use all RDKs as a base board for this and all other Rutronik adapter boards
- Easy integration of all other Rutronik adapter boards or other Arduino based evaluation boards via integrated Arduino headers
- Easy evaluation of the Epson Voice/Audio LSI S1V3G340 through provided GPIO pins directly on the board
- Available firmware examples for voice output of sensor data or alarm functions
- First class hard- and firmware support from our product experts and development engineers

Key Features

- Offers easy to use speech IC without traditional costly and time-consuming studio recordings by a person
- Generates high quality natural human voice with a high compression rate
- NOR Flash 64Mbit memory interfaced with Epson Voice/Audio LSI S1V3G340 via SPI enables large amounts of audio data to be stored
- Epson Voice/Audio solutions support both -existing concepts and new designs- by dedicated IC's for a seamless platform transformation adding Voice Guidance function
- 3.5mm stereo jack for stereo speakers or headphones
- Supports up to 12 languages

Markets & Applications

- Home Appliances
- Security/Alarms
- Door Locks/ Door Phones
- Healthcare
- Tracking Devices
- Goods for handicap/ Elder people

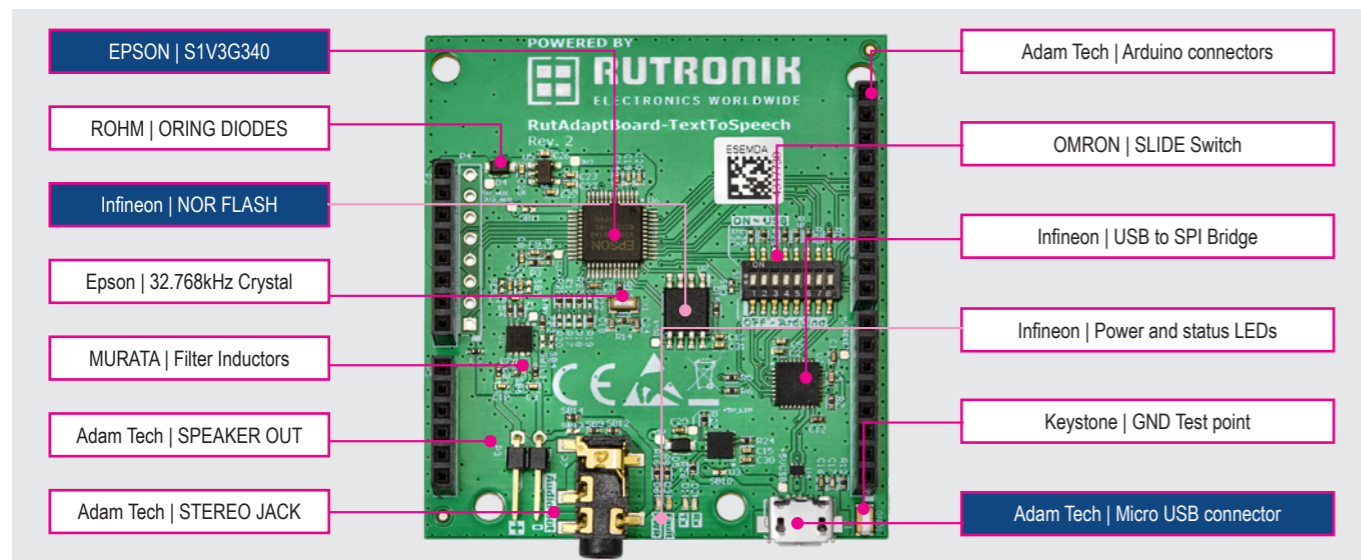

Small amount of ROM space to save space

	Format	sampling rate (kHz)	ADPCM (bit)	bitrate (kbps)	Speech time					
					1 (min)	2 (min)	3 (min)	4 (min)	5 (min)	10 (min)
others	ADPCM	16	4	64	480 (kB)	960 (kB)	1.440 (kB)	1.920 (kB)	2.400 (kB)	4.800 (kB)
		8	4	32	240 (kB)	480 (kB)	720 (kB)	960 (kB)	1.200 (kB)	2.400 (kB)
		8	3	24	180 (kB)	360 (kB)	540 (kB)	720 (kB)	900 (kB)	1.800 (kB)
EPSON	EOV (original)	16	-	16	120 (kB)	240 (kB)	360 (kB)	480 (kB)	600 (kB)	1.200 (kB)

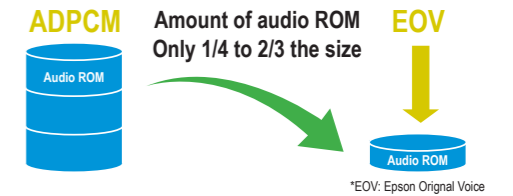

Block Diagram

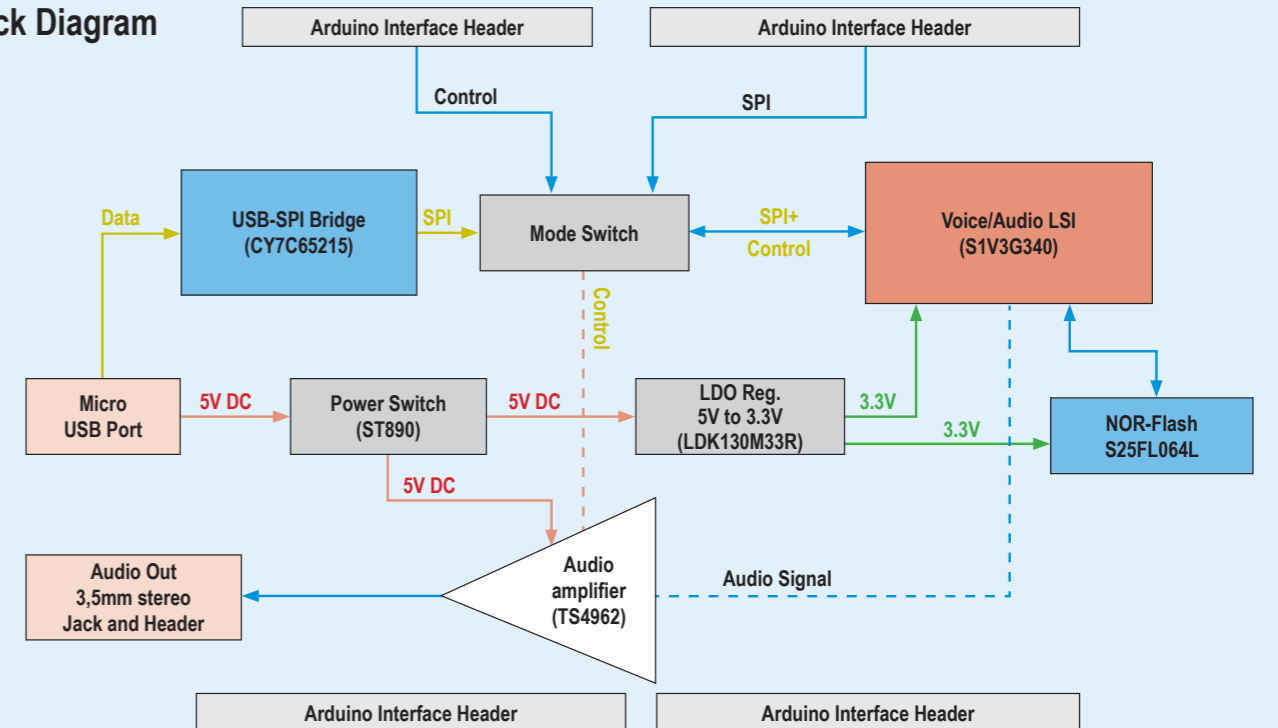

Usual process of adding a voice function

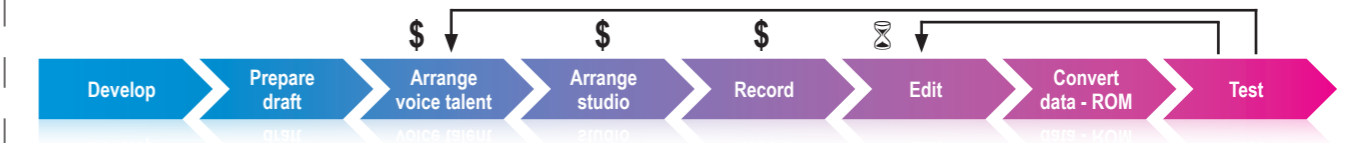

Process with Text To Speech board

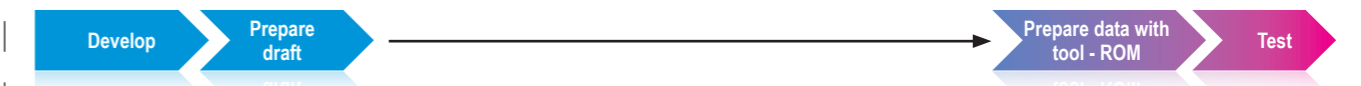



Adapter Board RAB1 – Sensorfusion

For intelligent sensor fusion

Benefits

- With state of the art sensors for all sensorfusion applications
- User can access all pins via supplied headers
- Operates on any evaluation board with Arduino Interface and perfect fit for our RDKs
- Can be combined with all of our other boards
- Many firmware examples are available on our homepage

Key Features

- Additional internal MEMS sensor for manipulation detection or navigation function
- I2C and SPI interface via Arduino compatible connectors
- Test Point connector for ground signal

Markets & Applications

- Building Automation
- Professional Kitchen
- HVAC
- Smart Farming

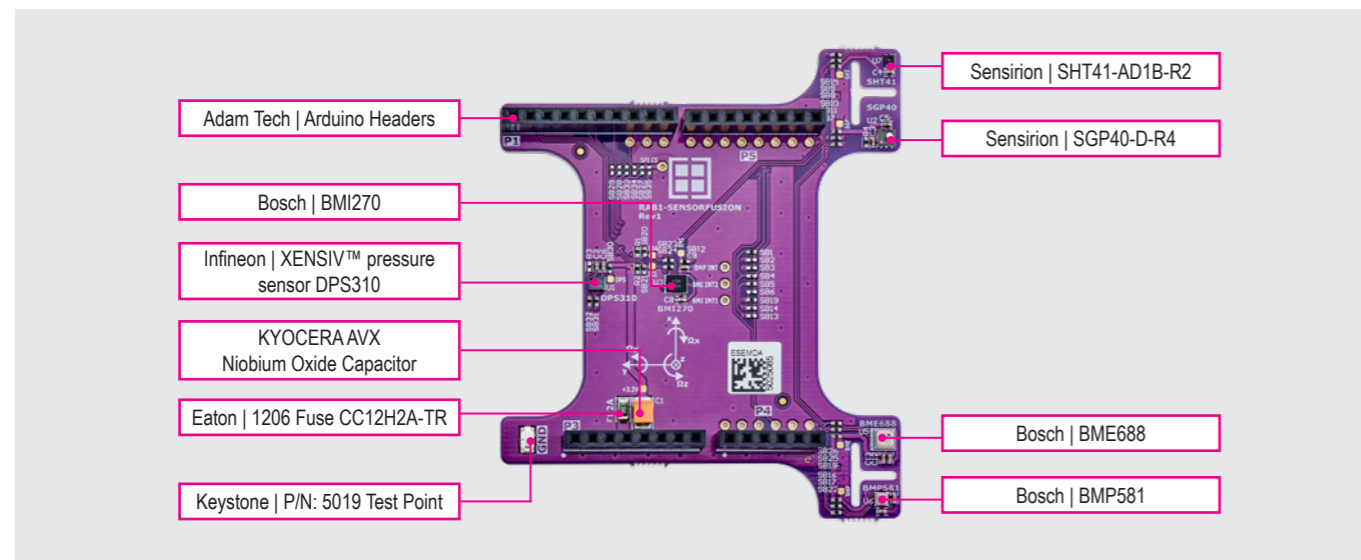

Adapter Board RAB2 – CO2

For best in class CO2 sensing

Benefits

- Easy evaluation of CO2 sensing
- Customer can decide which sensor and which measurement method fits the most
- Demo will be available at our trade fairs
- Stackable on RDKs and combination with other adapter boards possible

Key Features

- I2C and SPI interface via Arduino compatible connectors
- Test Point connector for ground signal

Markets & Applications

- Building Automation
- Professional Kitchen
- HVAC
- Smart City

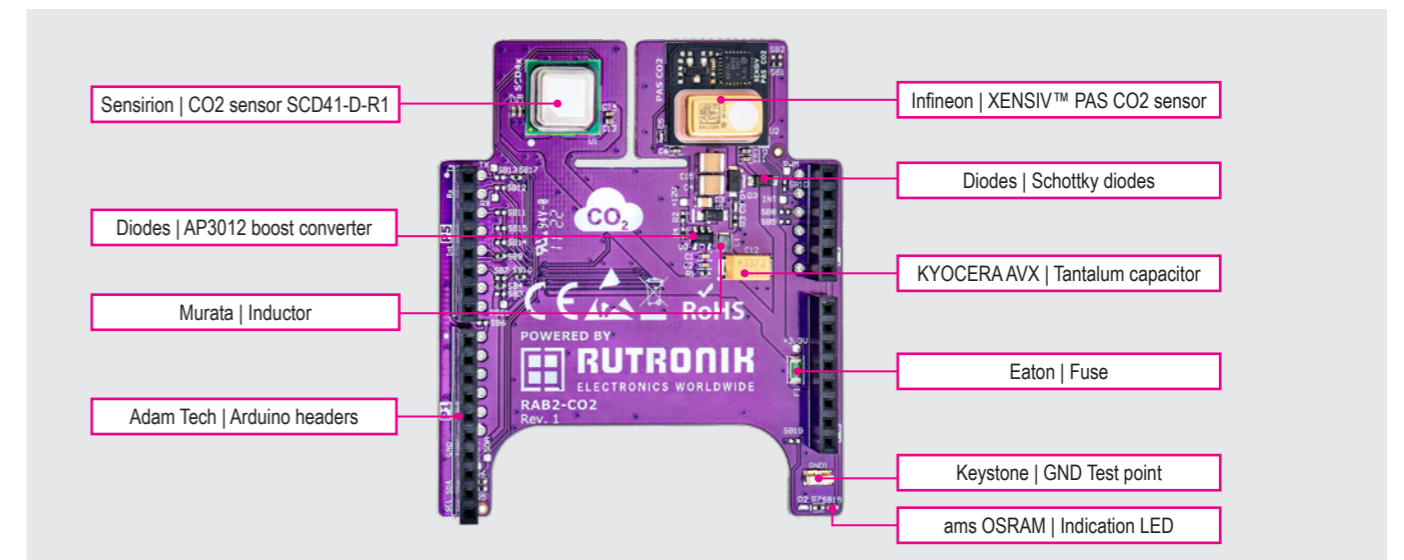



Adapter Board RAB3 – Radar

For distance measurement, people or surface detection

Benefits

- Fully integrated radar solution (Nisshinbo) and a discrete radar IC (Infineon) on one board
- Operates on any evaluation board with Arduino interface
- Can be combined with all of our other boards
- Firmware examples for distance measurement, people and surface detection

Key Features

- One board to test the possibility of a discrete development or the use of a fully integrated module
- Distance measurement and people detection with the use of our RSS smartphone App
- High stability against ambient noise
- Distance measurement up to 15m
- 3 Rx and 1 Tx antenna integrated

Markets & Applications

- Presence detection
- People counting
- Distance measurement

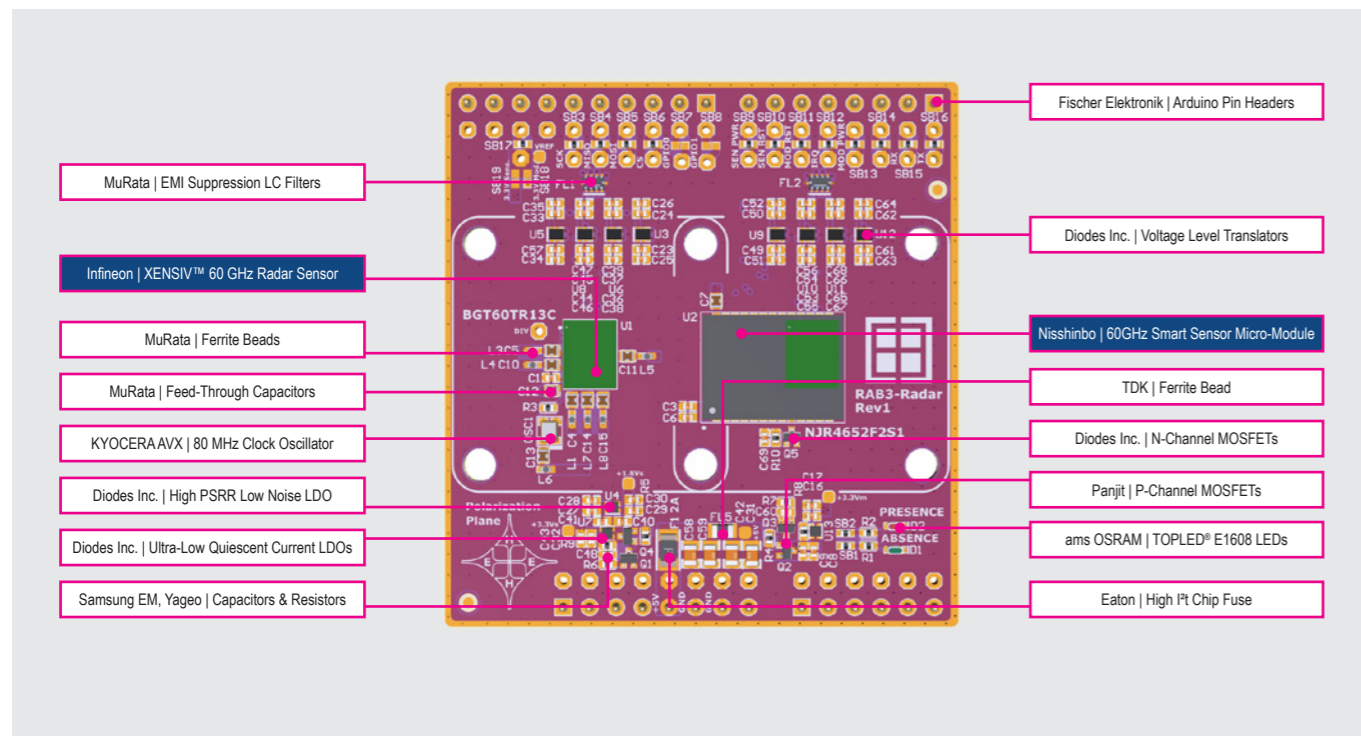

Adapter Board RAB4 – RTK

High precision outdoor navigation

Benefits

- Direct comparison of RTK and GPS possible because of Telit LE910 (with integrated standard GNSS)
- Operates on any evaluation board with Arduino interface
- Can be combined with all of our other boards

Key Features

- Up to 200 position measurements per second
- 1-2cm accuracy
- Absolut positioning thanks to Telit 4G module
- Relative positioning thanks to Unicore UM980 Module

Markets & Applications

- Agriculture equipment
- Self driving outdoor vehicles
- Robots
- Lawn mower
- Drones

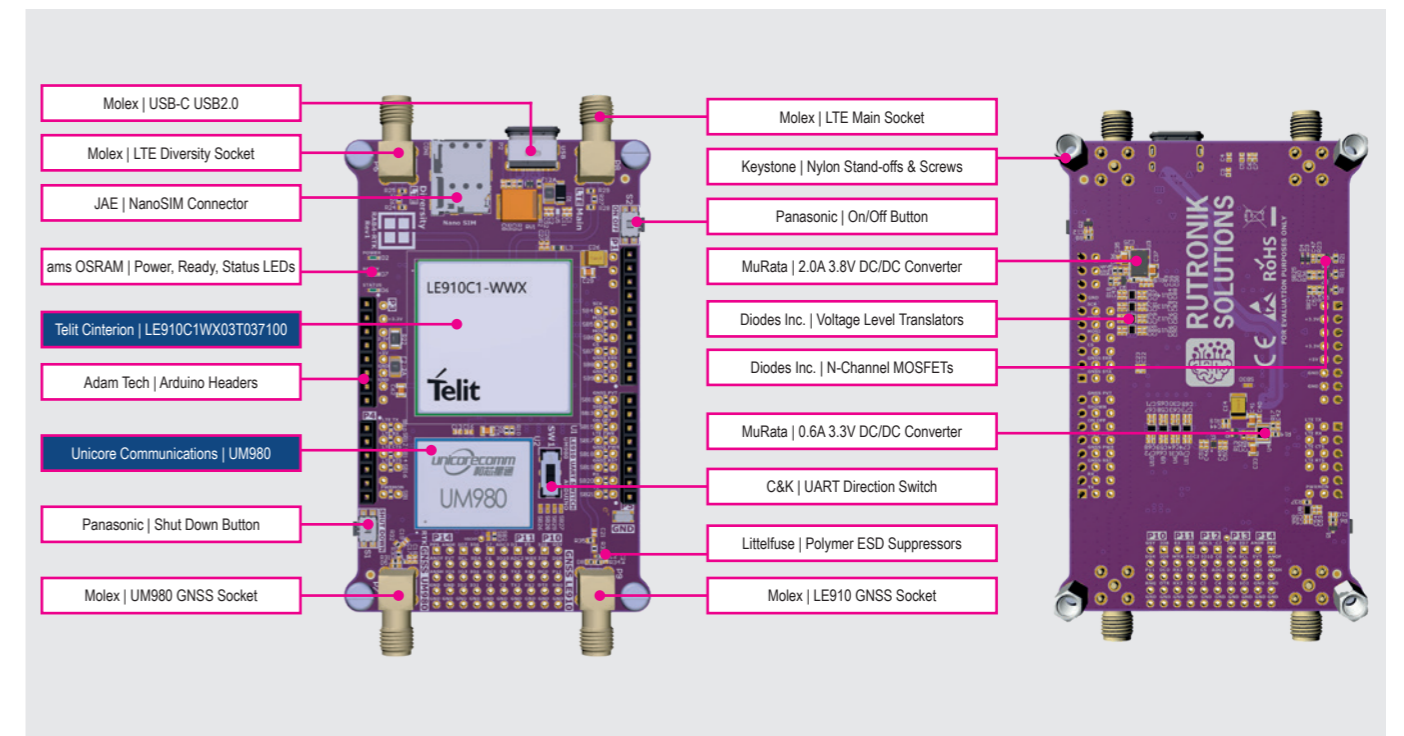

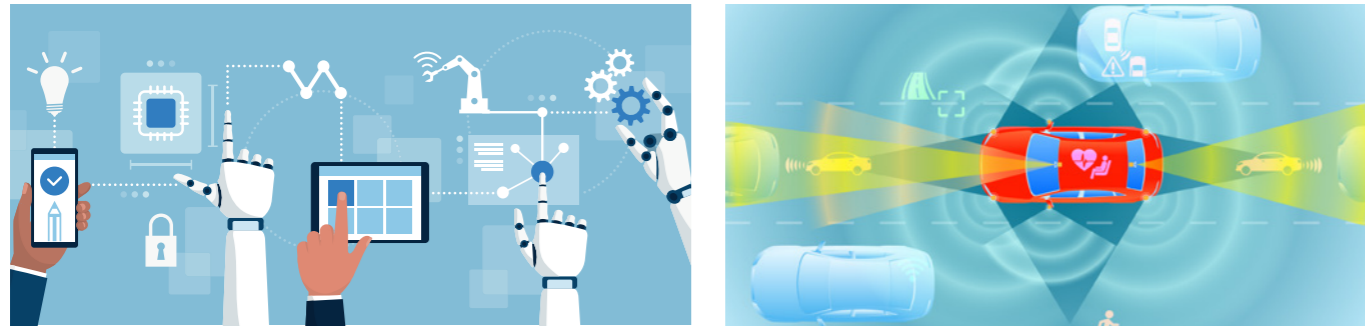

Adapter Board in cooperation with HMS – Communication via all common fieldbus and industrial ethernet networks

Benefits

- Various Anybus connector boards can be attached via the board connector e.g. PROFIBUS, Ethernet, CANopen, CC-Link, DeviceNet, etc.
- Easy integration of all other Rutronik adapter boards (e.g. Sensorfusion, CO2, etc.) or other Arduino based evaluation boards via integrated Arduino headers
- Built-in security features such as packet storm resistance, certificates, access control and more
- Free software updates whenever networks are revised
- Independent from new networks, IIoT, network upgrades, maintenance and conformance issues

Key Features

- Anybus CompactCom B-40-1 module connectors
- Pin header selects the power source between Arduino and DC input
- UART or SPI interface via Arduino compatible connectors
- Auxiliary 5V power source terminal
- LED indicators for power, status and network activity indication
- Test point connector for ground signal
- SMD standoffs for M3 screws

Markets & Applications

- Realtime communication
- Functional safety
- Control and automation
- Security
- Industrial automation
- Medical
- HMI/Displays

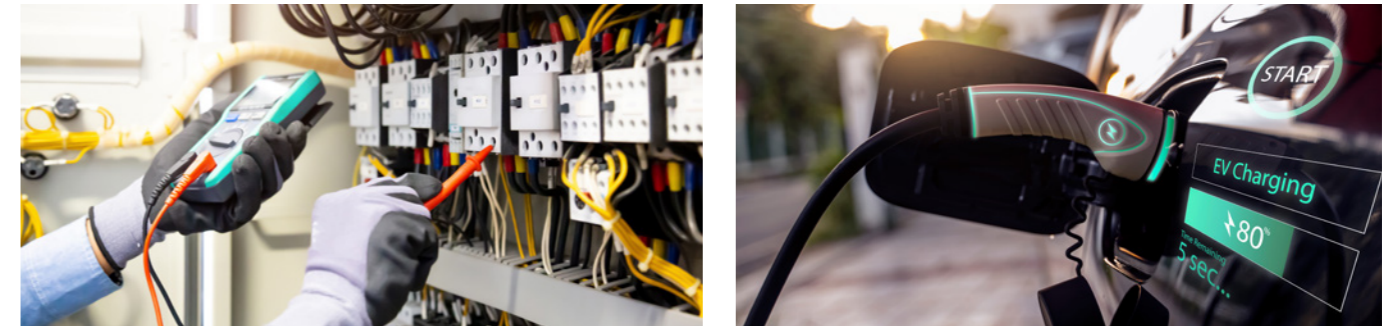
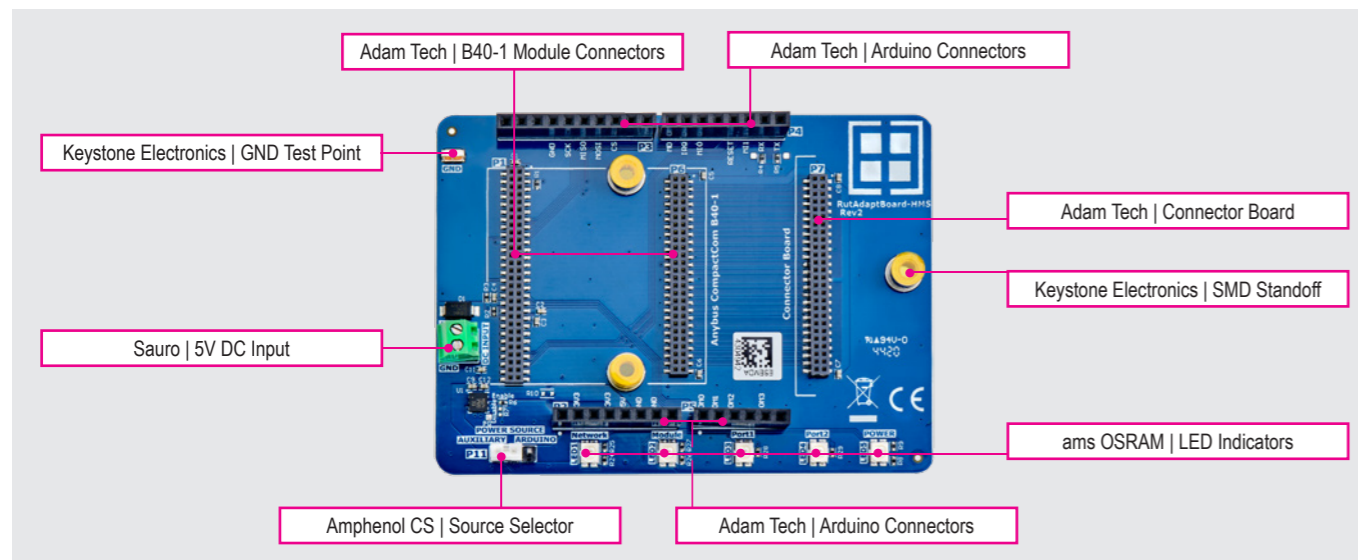

800 VDC Bi-Directional HV-Switch State-of-the-art innovative bi-directional 800 V eFuse

Benefits

- Innovative new trend for protecting user and hardware in high power applications
- Operates at full power with less than 25W of losses without requiring active cooling
- Included preload function, continuous current monitoring and overcurrent protection
- Protects both power source, cabling and connected load
- Fast disconnect keeps rest of boardnet unaffected from short circuit in load
- Pre-charging enables loading of connected DC-Link capacitors
- Solid State Switch, no arcing, no contact wear
- Feedback of actual voltage and current values enables load monitoring from remote

Key Features

- SiC MOSFETs and a VOA300 optocoupler
- Designed to handle continuous power up to 40kW
- Shut down after a fault - 2.5µs
- Developed as reference design for continuous load power up to 40 kW
- Bidirectional capability handles both motor and regenerative loads
- Overcurrent protection, ultrafast switch-off (~2.5 µs)
- Protection against overtemperature
- Pre-charging of capacitive loads
- Solid State Switch with SiC-MOSFETs
- Operation via push-buttons or communication bus

Markets & Applications

- Current sensing
- Power supply
- Galvanic isolation
- Protection & Discretes
- Automotive HV-switching
- Fuse & contactor replacement in HV-boardnet
- Switching of HV-DC-currents in Ex-protected areas
- Load control and monitoring

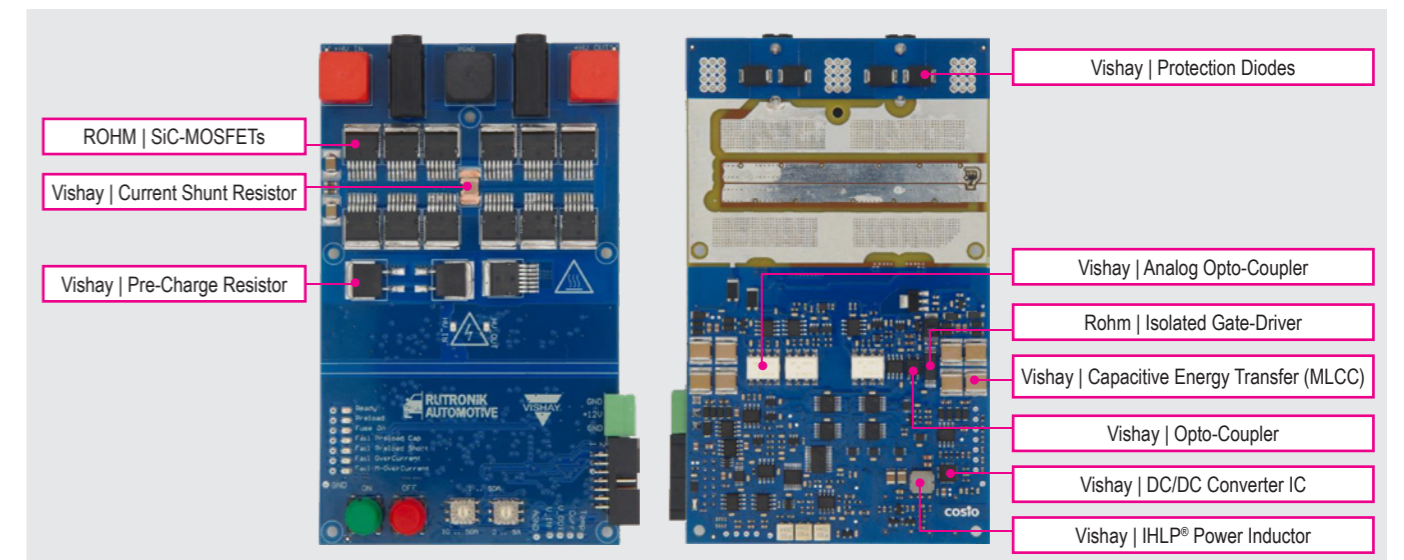

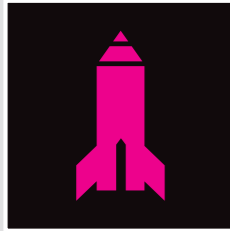

- Hardware developed by Rutronik serving as a proof of concept for system solutions in new markets and new technologies
- Partially based on Rutronik IP
- Development based on cooperations with leading universities and institutions
- Rutronik is following an IP protection program within the research programs
- Fusion of the know-how of suppliers on one board with the product know-how of Rutronik
- Fusion of the research know-how of universities and Rutronik know-how

Customer advantage

- Ready proof of concept on research level
- Combination of scientific know-how and newest products
- Therefore greater competitive advantage regarding know-how and time to market



RESEARCH LEVEL

Innovation Level	Faster Time to Market	Consulting	Special HW (Rutronik)	SW Adaption	Close Cooperation	RUT IP/ Partner IP

Board - Overview



HESS



Electronic Nose



Concept Phase

Odor Killer



Concept Phase

Virus Killer



Concept Phase

Insect Scare



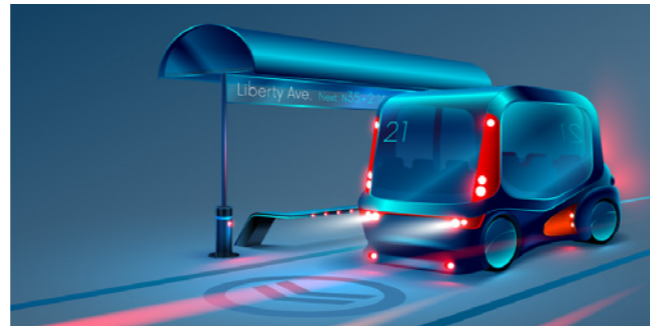

HESS – Hybrid Energy Storage System in cooperation with HS Zwickau

Benefits

- Extended battery lifetime
- Ultra-fast detection and switching
- Combines the advantages of Li-Ion cells and super caps
- Adjustable battery current limiter
- Recuperation charging available
- High Power Scalable from 1KW to 10KW at 36V-72V

Key Features

- High speed analog/ mixed signal processing
- di/dt detection within ns
- Reverse current detection
- Recuperation current detection
- High speed control logic of a buck or MOS boost converter
- Anti-cross conduction drive control
- Ultra fast detection (ns) and switching (μ s) algorithm
- Extremely high peak current performance
- Predicted battery lifetime and state-of-health (SoH)
- Best trade-off between energy density, power density, capacity, cost, weight and volume of the storage system

Markets & Applications

- LEV
- City busses
- Golf carts
- Material Handling
- Marine
- Gardening
- Industrial Vehicle
- Agriculture
- Aviation

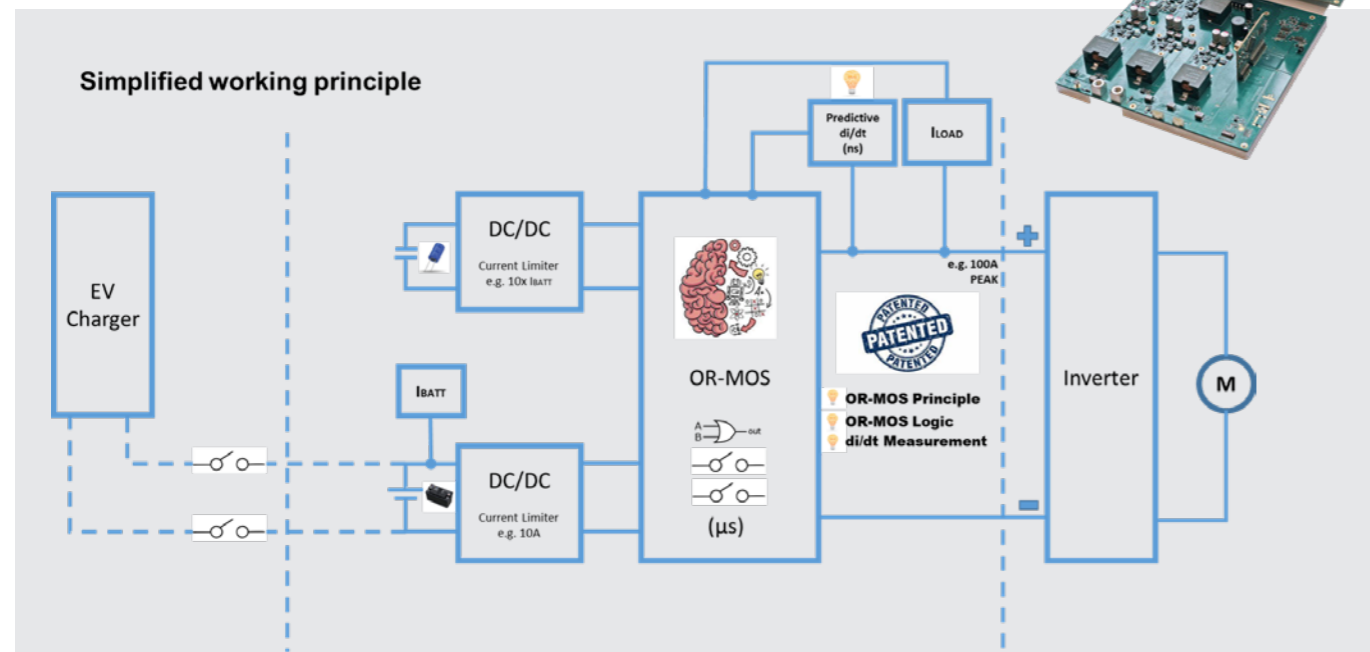
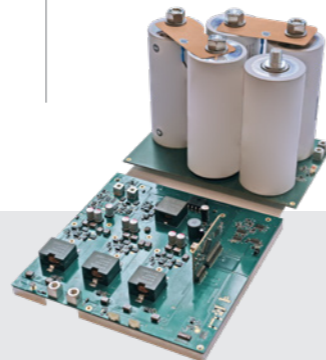

	Li-Ion Cells	Super Cap	Combination Li-Ion Cell + Super-Cap
Power Capability (W/kg)	++	+++	+++
Energy Density (Wh/Dimensions)	++	-	++
Specific Energy(Wh/kg)	++	+	+
Cycle Life	0	+++	+++
Calendar Life	+	++	+++
Price	-	0	0
Self-Discharge	++	-	++
Temperature behavior	0	++	++
Reliability	0	++	++
Fast Charging	0	+++	+++

Scoring : +++ extremely good; ++, very good + good 0 neutral - disadvantage

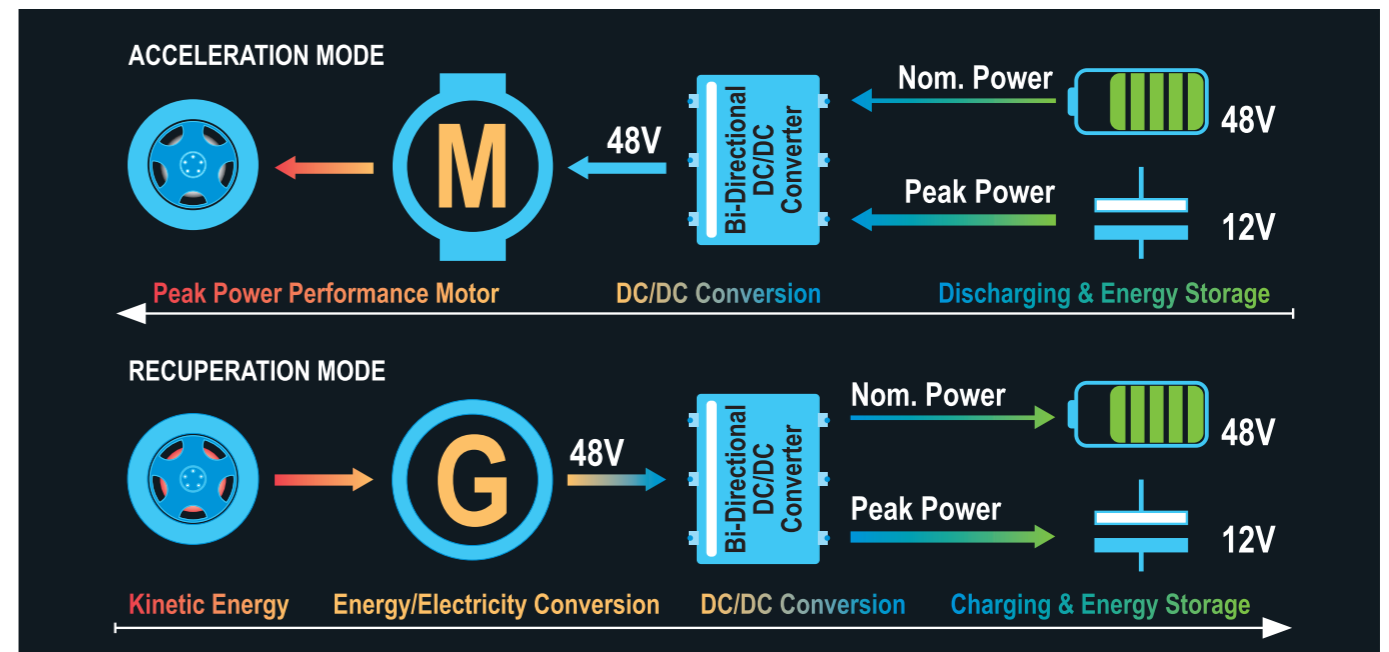



Electronic Nose

Working like a human sensory organ

The electronic nose works like the human sensory organ. Like our nose the system detects volatile compounds and volatile organic compounds (VOC) that emit odors or can be harmful to one's health. This system selectively stimulates the compounds, analyses and characterizes the behavior of the compounds physically and biochemically. When observing volatile compounds in the air, the state is not stationary, it is a volatile state. The status depends on the chemical and physical parameters that are not constant. Thus, a volatile and multidimensional and ever changing system exists.

Markets & Applications

- Home Appliances
- Gas detection
- Liquid detection
- Perishable food evaluation



Odor Eliminator

Detect, analyze and eliminate smells for fresh air in every room

The odor eliminator makes use of the odor destroying properties of UVA LEDs. Volatile compounds and volatile organic compounds (VOC) can cause odors and can be harmful in certain concentration. The state is not stationary, it is a volatile state. The status depends on the chemical and physical parameters that are not constant. Thus, a volatile and multidimensional and ever changing system exists. The odor eliminator is a system that selectively stimulates volatile compounds. The molecular composition of the VOCs can be changed, analyzed and destroyed with the help of UVA LEDs.

Concept Phase

Markets & Applications

- White Goods
- Indoor Applications
- Air purifier



Virus Killer

Safe UVC-LED disinfection of viruses & bacteria

The system solution virus eliminator makes use of the disinfecting effect of UVC LEDs. When observing volatile compounds and volatile organic compounds (VOC) in the air, the state is not stationary, it is a volatile state. The status depends on the chemical and physical parameters that are not constant. The virus eliminator is a safe and closed system, that precisely destroys the molecular and organic composition of viruses and bacteria in the air.

Concept Phase

Markets & Applications

- Home Appliances
- Water taps
- Refrigerators & Freezers



Insect Scare

Unique technology to manipulate the sense of insects to keep them away

The insect scare is a system solution that selectively influences the senses of insects. Depending on the insect either the odors need to be manipulated by ionization of the air, or the hairs of the insect by sending out specific signals to stimulate them. The influence of smells only occur within a defined radius. The sense of smell is being limited, so that the insects cannot sense stimuli within that radius. This can be for example the smell of fruit or meat. In general the technical solution can be adapted to a variety of insects.

Concept Phase

Markets & Applications

- Table devices
- Windows
- Outdoor devices

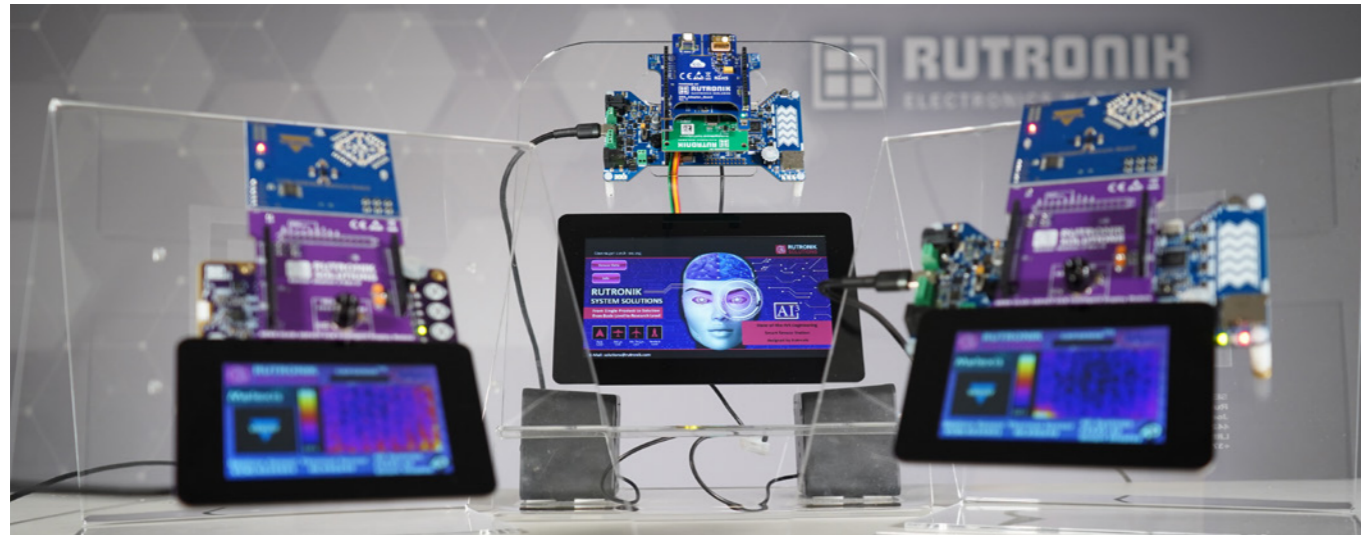

Smart Sensor Station 1

The Smart Sensor Station 1 shows the concept with a perfect combination of our RDK2 with the adapter boards TextToSpeech, Sensorfusion and CO2 with an additional smart display to visualize the data.

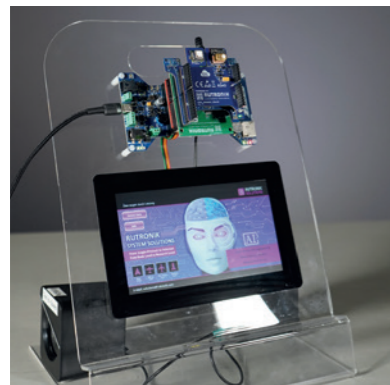

- RDK2 ensures smooth communication of the boards
- TextToSpeech provides an acoustic data and alarm output
- RAB1 provides a large amount of available sensor data
- RAB2 provides a direct comparison of two CO2 sensors
- A smart display provides visual data output and easy navigation

Included boards: RDK2 | Adapter Board - TextToSpeech
RAB1 - Sensorfusion | RAB2 - CO2 | 4DSYSTEMS display

Smart Sensor Station 2

The Smart Sensor Station 2 shows the concept with the usage of RDK2 or RDK3 and the adapter boards for a FIR thermal- and IR gesture detection with an additional smart touch display to visualize the data

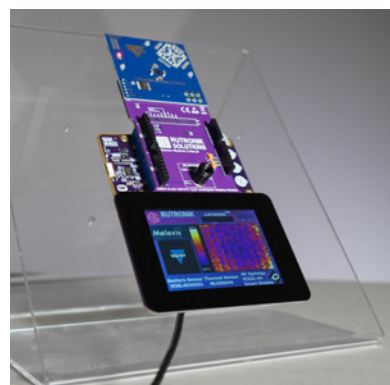

- RDK2 or RDK3 ensures smooth communication of the boards
- IR gesture detection board for low cost gesture control
- FIR thermal array sensor for people counting, presence detection or temperature measurement
- CSX capacitive CAPSENSE™ buttons for touch control
- Smart touch display provides visual data output and easy navigation

Included boards: RDK2 or RDK3 | Evaluation Board – FIR thermal sensor
Evaluation Board – VCNL4035X01 | 4DSYSTEMS Display

Rutronik System Solutions APP

Utilize Rutronik System Solutions for iOS to:

- Demonstrate Bluetooth functions.
- Test various Rutronik development boards.
- Retrieve live sensor data (including environmental, radar, real-time kinematic, CO₂, and time-of-flight sensors).
- Explore new and trending repositories

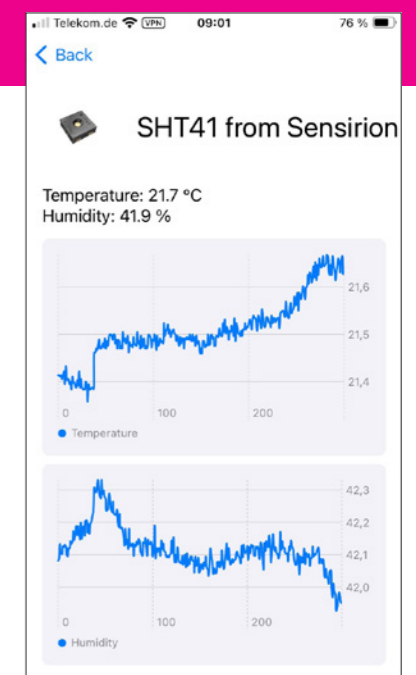
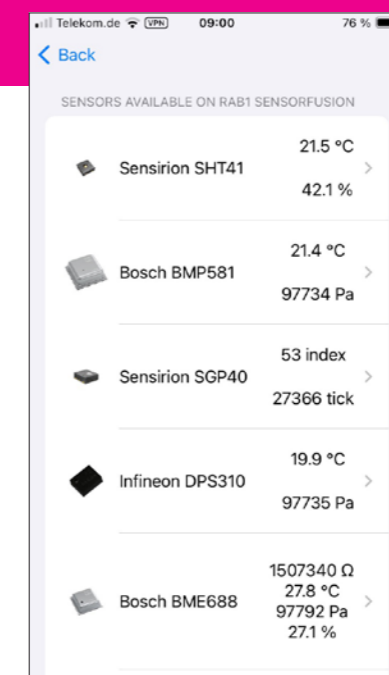
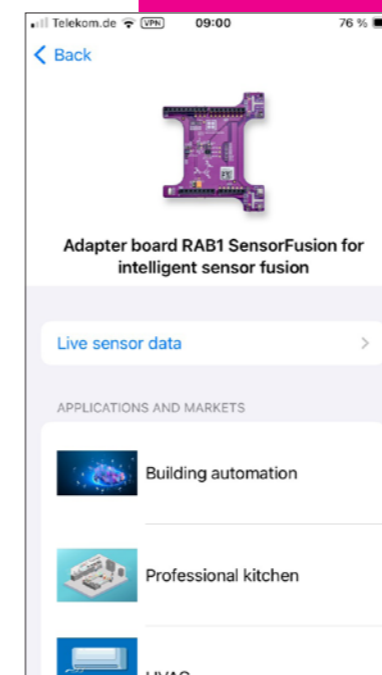
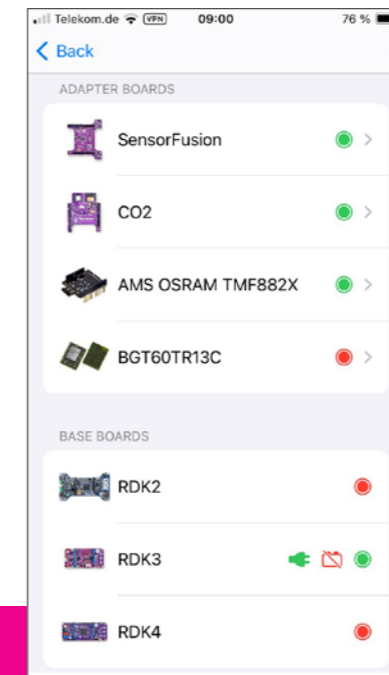
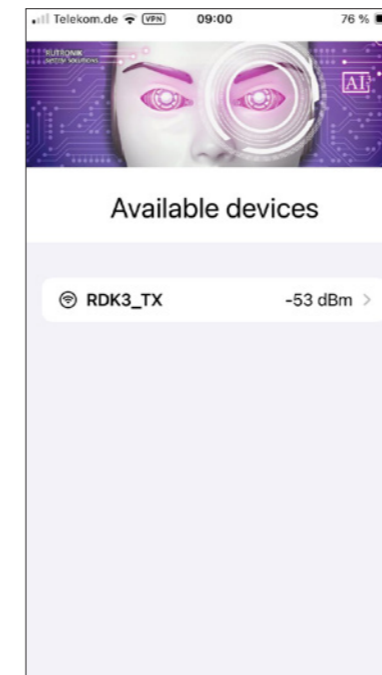
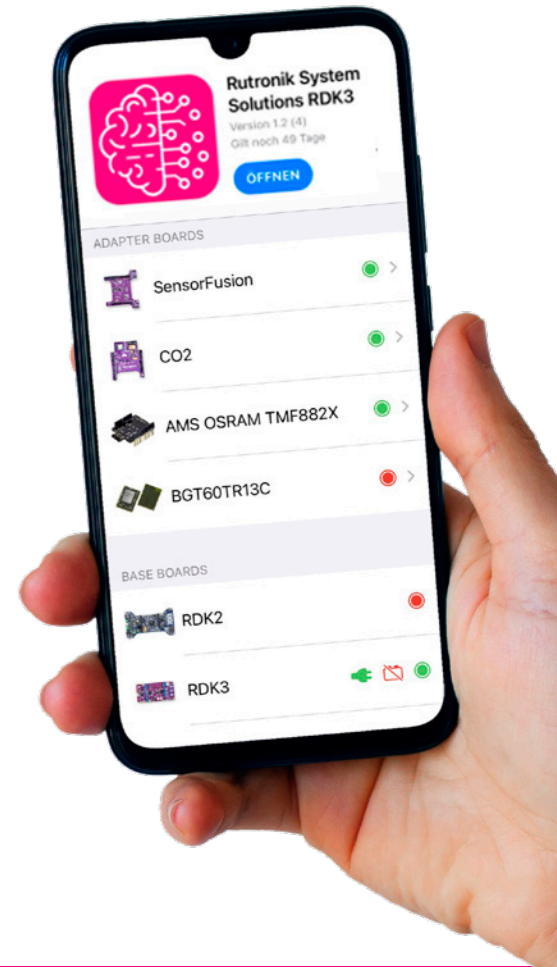

ModusToolbox™ & Friends program

As partner of the ModusToolbox™ & Friends program you can find all our RDKs in the ModusToolbox™ development environment

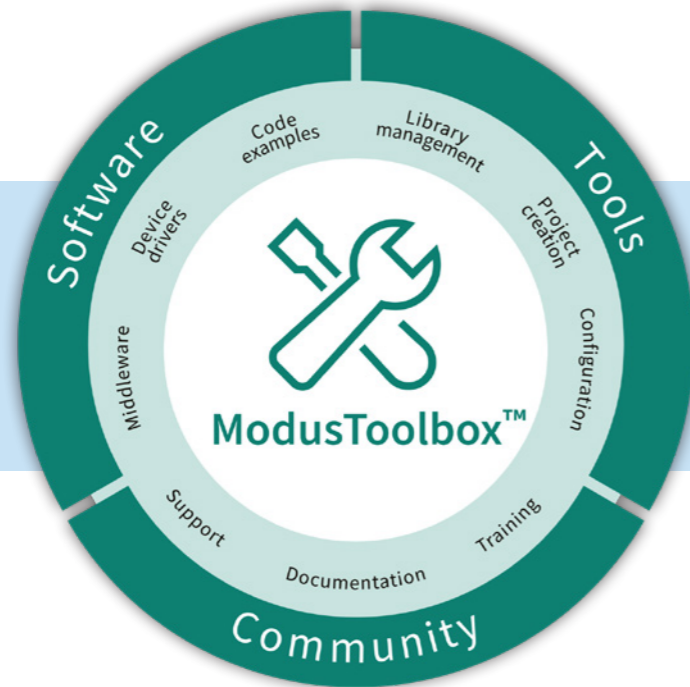

Quelle: Infineon

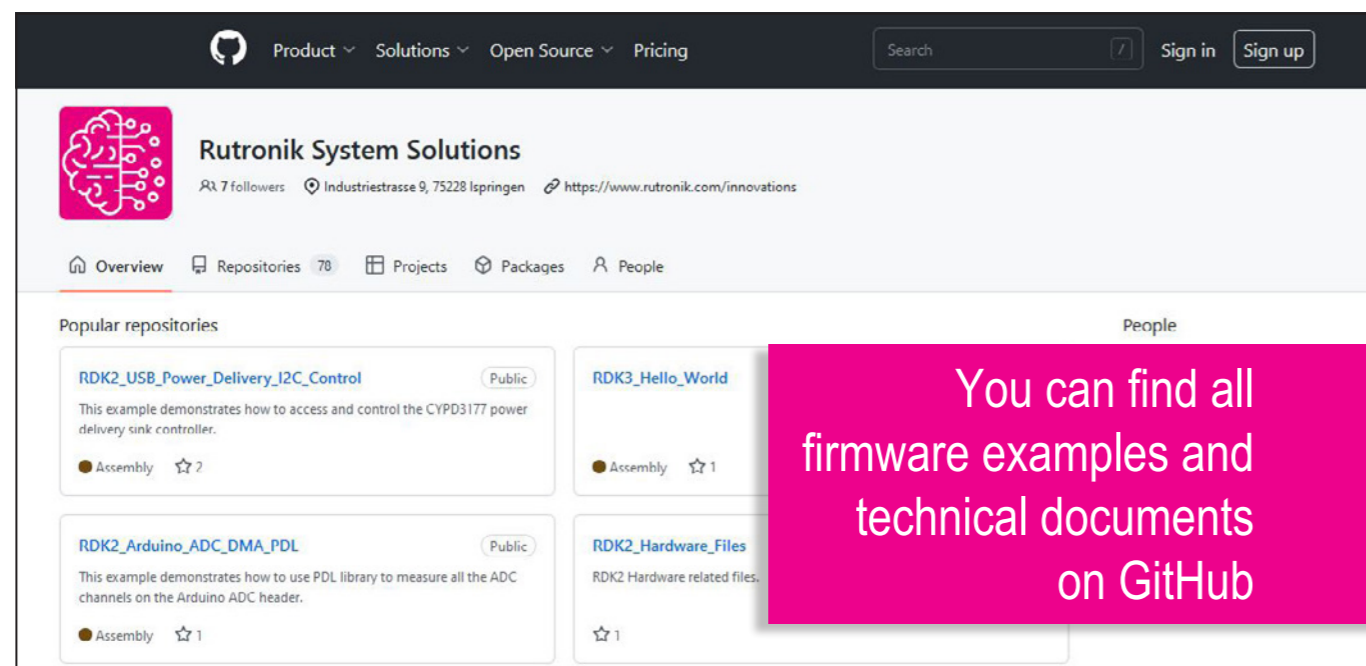

You can find all firmware examples and technical documents on GitHub

Find us on www.rutronik.com



- Information and descriptions about all available Rutronik boards
- Download section for all technical documents and other information material
- Contact form for customer requests and questions
- Information about Rutroniks future markets
- Direct link to our R24 shop to directly order the boards

Electronics for Future Markets



INNOVATION & FUTURE DNA



Rutronik Elektronische Bauelemente GmbH
Industriestraße 2 | 75228 Ispringen | Deutschland | rutronik.com